



Mayor Elizabeth Olson
Council Member Durwin Tomperi
Council Member Dan Warmbold
Council Member Mike Netland
Council Member Jody Bjornson

**City of Menahga
Special/Work Session Meeting
Monday, August 28, 2023
6:00 pm**

City Council Chambers
115 2nd Street NE
Menahga MN 56464

www.cityofmenahga.com

Agenda

- a. Call to Order
- b. Roll Call
- c. Pledge of Allegiance
- d. Department Reports
 - Police – Amy Lane
 1. Monthly Report
 2. Narcan Requirements
 3. Body Cameras
 - Public Works/Streets – Ron Yliniemi
 1. Monthly Report
 2. Breakaway Mailbox Requirement
 3. Payloader Tires
 - Liquor Store –
 1. Monthly Report
 - Park/Beach/Mowing/Building Maintenance
 1. Electrical at City Hall
 2. Garage Door Repair
 3. Long-Term Campsites
 - Administration – Jensine Kurtti
 1. Monthly Report
 2. Miles for Michael
 3. Resolution 2023-32 – Get Hooked on Fishing – Gary Ryhti
 4. Public Hearing Opioid Settlement – Wadena County
 5. Advertising Pricing – Fargo Forum and Star Tribune
 6. ECPN – Betty Thomsen
 7. Administrative Staff Hiring

- Fire – Dave Kicker
 1. Monthly Report

e. New Business

1. none

f. Unfinished Business

1. none

g. Consideration of Bills

1. Batch #082823PAY - \$78,879.29 and Batch #UBPOSTAGE - \$ _____

h. Adjournment

We ask that once the meeting is over, that everyone leave the building so it may be locked.



MENAHGA Police Department

115 2ND Street NE
Menauga, MN 56464
PH:218.564.4516

City Council Monthly Reporting July 27, 2023 – August 24, 2023

Total Calls: 132

Time: 9:26:12AM		Agency: Menauga Police							
Report: CP903		Date: 07-27-2023	Thru: 08-24-2023						
Activity		Sun	Mon	Tue	Wed	Thur	Fri	Sat	Total
Agency:	MPD Menauga Police								
01021	Call By Phone	0	0	0	0	1	0	0	1
01029	Stolen Or Wanted	0	0	0	0	1	1	0	2
01038	Traffic Stop	5	6	3	3	10	1	6	34
01050	Accident-Property Damage	0	0	0	0	0	1	0	1
01074	Theft Complaint	0	0	0	0	0	1	0	1
01075	Juvenile Trouble	0	1	0	0	0	0	1	2
01078	Ambulance Run (LE)	1	2	1	1	0	0	1	6
01081	Alarm	0	0	1	1	1	0	0	3
01083	Disturbance-Noise Comp	0	0	0	0	0	1	0	1
911HA	911 Hangup Call	0	0	0	0	1	0	0	1
ASSIS	Assist Other Agency	0	0	3	0	0	0	1	4
CAMP	Campground Patrol	1	3	6	0	0	1	2	13
CHILD	Child Welfare	0	0	0	1	0	0	0	1
DOG	Dog Animal Complaint	1	2	1	1	0	1	0	6
DRIVE	Driving/Parking Complaint	1	3	4	0	3	3	0	14
GARBA	Garbage Complaint	0	1	0	0	0	0	0	1
INFOR	Information	0	1	0	0	0	0	0	1
LOST	Lost Property-Animal	0	0	1	0	0	0	0	1
NUISA	PUBLIC NUISANCE	0	0	0	0	2	0	0	2
OTHER	Other Calls	0	1	2	0	1	0	3	7
PRISO	Prisoner Transport	0	0	0	0	1	0	0	1
PROBA	Probation Check-Assist	0	1	0	0	0	1	1	3
PROPE	Property Watch	0	4	2	1	1	1	2	11
Speci	Special Service Detail	0	1	1	0	0	0	1	3
SUSPE	Suspicious Activity	1	1	1	0	0	0	0	3
TRAFF	Traffic Control	0	0	0	0	1	0	0	1
TRESP	Trespassing	0	0	0	0	1	0	0	1
VA	Vulnerable Adult Maltreat	0	0	1	0	0	0	0	1
VANDA	Vandalism	1	1	0	0	0	0	0	2
WEATH	Weather Incident	0	0	1	0	0	0	0	1
WELFA	Welfare Check	0	1	1	1	0	0	0	3
Menauga Police Agency Total		11	29	29	9	24	12	18	132

Citations: 1- Driving after Revocation, 2- No Proof of Insurance, 1- Passing on the Right, 2- Speeding

Squad Cars

2020 Chevrolet Tahoe
Officer J. White
Mileage: 40,950

2018 Ford Explorer
Chief A. Lane
Mileage: 70,674

2016 Ford Explorer
Officer D. Huotari
Mileage: 131,743

Miscellaneous Information

- Narcan Requirements and Policy
- Body Camera Policy/Public Hearing

EFFECTIVE DATE.

This section is effective August 1, 2023.

Sec. 16.

[626.8443] OPIATE ANTAGONISTS; TRAINING; CARRYING; USE.

Subdivision 1.

Training.

A chief law enforcement officer must provide basic training to peace officers employed by the chief's agency on:

- (1) identifying persons who are suffering from narcotics overdoses; and
- (2) the proper use of opiate antagonists to treat a narcotics overdose.

Subd. 2.

Mandatory supply.

A chief law enforcement officer must maintain a sufficient supply of opiate antagonists to ensure that officers employed by the chief's agency can satisfy the requirements of subdivision 3.

Subd. 3.

Mandatory carrying.

Each on-duty peace officer who is assigned to respond to emergency calls must have at least two unexpired opiate antagonist doses readily available when the officer's shift begins. An officer who depletes their supply of opiate antagonists during the officer's shift shall replace the expended doses from the officer's agency's supply so long as replacing the doses will not compromise public safety.

Subd. 4.

Authorization of use.

(a) A chief law enforcement officer must authorize peace officers employed by the chief's agency to perform administration of an opiate antagonist when an officer believes a person is suffering a narcotics overdose.

(b) In order to administer opiate antagonists, a peace officer must comply with section 151.37, subdivision 12, paragraph (b), clause (1).

Sec. 17.

REPEALER.

Minnesota Statutes 2022, section 152.092, is repealed.

EFFECTIVE DATE.

This section is effective August 1, 2023.

MENAHGA POLICE DEPARTMENT

Policy Number: 37

Subject: Naloxone Program

Purpose and Scope

The Menahga Police Department recognizes the value of providing an intermediate medical response to a recognized opioid overdose by administering intranasal naloxone in emergency situations for patients 12 weeks of age and older. This policy establishes guidelines for the storage and administration of intranasal naloxone by all trained members of the Menahga Police Department.

Definitions

Opioid: Substances occurring naturally in the body, derived from the poppy plant (Opium), or synthesized to have similar effects, that work on the nervous system and are used to treat pain. These include but are not limited to the following: Morphine, heroin, hydromorphone, hydrocode, oxycodone, oxymorphone, and fentanyl.

Naloxone (Narcan®): Drug synthesized to be an opioid antagonist.

Policy

The policy of this office in dealing with an opioid overdose situation shall be:

- a. To obtain and safely maintain control of the incident until more highly qualified medical personnel arrive on scene.
- b. When safe to do so, assess the patient and determine signs of opioid toxicity by observing:
 1. slow (less than 10 breaths per minute) or shallow breathing
 2. central Nervous System depression
 3. pinpoint pupils
 4. respiratory arrest and/or cardiac arrest
- c. If opioid overdose is suspected and the patient is not in cardiac arrest, administer Naloxone by:

Officer Safety When Naloxone is used on a patient and it reverses the opioid effects, the patient may go into immediate withdrawal and become agitated. This will become a safety risk. Deputies will need to maintain scene safety and be prepared to deal with an agitated/combatative patient.

 1. Making sure the patient's nose is relatively clear
 2. Open package
 3. Place atomizer firmly in the first nostril and briskly compress syringe to administer 4mg/0.1mL prefilled spray
 4. Continue rescue breaths using the bag valve mask
 5. If no response within 2-3 minutes, repeat dose in opposite nostril and consider other medical causes
- d. If patient is in cardiac arrest, begin AED actions: if NO SHOCK advised, then follow (c) above
- e. To provide assistance to and security for medical staff that arrive on scene.
- f. Naloxone shall be maintained at temperatures between 59 and 77 degrees Fahrenheit. Excursions may be permitted up to 104 degrees Fahrenheit. Deputies shall not allow their issued Naloxone doses to freeze.
- g. A report shall be completed if Naloxone is administered, regardless of effect.
- h. The on-line MDH administration form shall be completed

CAUTION: Naloxone may elicit opioid withdrawal leading to nausea, vomiting, agitation and/or tachycardia. Reversal of opioid toxicity, including sedating effect, may unveil the effects of other non-sedating drugs.

* Body Cameras *

626.8473 PORTABLE RECORDING SYSTEMS ADOPTION; WRITTEN POLICY REQUIRED.

Subdivision 1. Definition. As used in this section, "portable recording system" has the meaning provided in section 13.825, subdivision 1.

* **Subd. 2. Public comment.** A local law enforcement agency must provide an opportunity for public comment before it purchases or implements a portable recording system. At a minimum, the agency must accept public comments submitted electronically or by mail, and the governing body with jurisdiction over the budget of the law enforcement agency must provide an opportunity for public comment at a regularly scheduled meeting. *

Subd. 3. Written policies and procedures required. (a) The chief officer of every state and local law enforcement agency that uses or proposes to use a portable recording system must establish and enforce a written policy governing its use. In developing and adopting the policy, the law enforcement agency must provide for public comment and input as provided in subdivision 2. Use of a portable recording system without adoption of a written policy meeting the requirements of this section is prohibited. The written policy must be posted on the agency's website, if the agency has a website.

(b) At a minimum, the written policy must incorporate the following:

(1) the requirements of section 13.825 and other data classifications, access procedures, retention policies, and data security safeguards that, at a minimum, meet the requirements of chapter 13 and other applicable law;

(2) procedures for testing the portable recording system to ensure adequate functioning;

(3) procedures to address a system malfunction or failure, including requirements for documentation by the officer using the system at the time of a malfunction or failure;

(4) circumstances under which recording is mandatory, prohibited, or at the discretion of the officer using the system;

(5) circumstances under which a data subject must be given notice of a recording;

(6) circumstances under which a recording may be ended while an investigation, response, or incident is ongoing;

(7) procedures for the secure storage of portable recording system data and the creation of backup copies of the data; and

(8) procedures to ensure compliance and address violations of the policy, which must include, at a minimum, supervisory or internal audits and reviews, and the employee discipline standards for unauthorized access to data contained in section 13.09.

History: 2016 c 171 s 6

PORTABLE AUDIO / VIDEO RECORDERS

POLICY 16

Purpose and Scope

This policy provides guidelines for the use of portable audio/video recording devices by members of this Department while in the performance of their duties (Minn. Stat. § 626.8473). Portable audio/video recording devices include all recording systems whether body-worn, hand-held, or integrated into portable equipment.

This policy does not apply to mobile audio/video recordings, interviews, or interrogations conducted at any City of Menahga facility, undercover operations, wiretaps, or eavesdropping (concealed listening devices).

Definitions

Portable recording system - A device worn by a member that is capable of both video and audio recording of the member's activities and interactions with others or collecting digital multimedia evidence as part of an investigation and as provided in Minn. Stat. § 13.825.

The Menahga Police Department may provide members with access to portable recorders for use during the performance of their duties. The use of recorders is intended to enhance the mission of the Department by accurately capturing contacts between members of the Department and the public.

Member Privacy Expectation

All recordings made by members on any agency-issued device at any time or while acting in an official capacity of this Department, regardless of ownership of the device, shall remain the property of the City. Members shall have no expectation of privacy or ownership interest in the content of these recordings.

Member Responsibilities

Prior to going into service, each uniformed and non-uniformed member will be responsible for making sure that he/she is equipped with a portable recorder issued by the agency, and that the recorder is in good working order (Minn. Stat. § 13.825). This consists of conducting a "Test" recording and labeling it as such. If the recorder is not in working order or the member becomes aware of a malfunction at any time, the member shall promptly report the failure to his/her supervisor and obtain a functioning device as soon as reasonably practicable.

Uniformed members should wear the recorder in a conspicuous manner or otherwise notify persons that they are being recorded, whenever reasonably practicable (Minn. Stat. § 626.8473).

Any member assigned to a non-uniformed position may carry an approved portable recorder at any time the member believes that such a device may be useful. Unless conducting a lawful recording in an authorized undercover capacity, non-uniformed members should wear the recorder in a conspicuous manner when in use or otherwise notify persons that they are being recorded, whenever reasonably practicable.

When using a portable recorder, the assigned member shall record his/her name, employee number and the current date and time at the beginning and the end of the shift or other period of use, regardless of whether any activity was recorded. This procedure is not required when the recording device and related software captures the user's unique identification and the date and time of each recording.

Members should document the existence of a recording in any report or other official record of the contact, including any instance where the recorder malfunctioned or the member deactivated the recording (Minn. Stat. § 626.8473). Members should include the reason for deactivation.

Activation of the Audio/Video Recorder

This policy is not intended to describe every possible situation in which the recorder should be used, although there are many situations where its use is appropriate. Members will activate the recorder any time the member believes it would be appropriate or valuable to record an incident, and anytime a "Call For Service" is generated where the member is in contact with the general public (exceptions listed below).

The recorder should be activated in any of the following situations:

- (a) All enforcement and investigative contacts including stops and field interview (FI) situations
- (b) Traffic stops including, but not limited to, traffic violations, stranded motorist assistance and all crime interdiction stops
- (c) Self-initiated activity in which a member would normally notify Dispatch
- (d) Any other contact that becomes adversarial after the initial contact in a situation that would not otherwise require recording

The recorder should not be activated in any of the following situations:

- (a) When attending public events, such as; school functions, fairs, picnics ect.

- (b) When entering a medical facility (HIPAA laws), (*Activation allowed only for recording investigative statements.*)
- (c) Civil Commitment Transports
- (d) Whenever a "Call For Service " is generated and the activity reflects the above mentioned situations
- (e) When entering the secure area of a Jail or Detention facility

Members should remain sensitive to the dignity of all individuals being recorded and exercise sound discretion to respect privacy by discontinuing recording whenever it reasonably appears to the member that such privacy may outweigh any legitimate law enforcement interest in recording. Requests by members of the public to stop recording should be considered using this same

criterion. Recording should resume when privacy is no longer at issue unless the circumstances no longer fit the criteria for recording.

At no time is a member expected to jeopardize his/her safety in order to activate a portable recorder or change the recording media. However, the recorder should be activated in situations described above as soon as reasonably practicable.

Cessation of Recording

Once activated, the portable recorder should remain on continuously until the member reasonably believes that his/her direct participation in the incident is complete or the situation no longer fits the criteria for activation. Recording may be stopped during significant periods of inactivity such as report writing or other breaks from direct participation in the incident.

Surreptitious Recordings

Minnesota law permits an individual to surreptitiously record any conversation in which one party to the conversation has given his/her permission (Minn. Stat. § 626A.02).

Members of the agency may surreptitiously record any conversation during the course of a criminal investigation in which the member reasonably believes that such a recording will be lawful and beneficial to the investigation.

Members shall not surreptitiously record another agency member without a court order unless lawfully authorized by the Chief of Police or the authorized designee, for the purpose of conducting a criminal or administrative investigation.

Explosive Device

Many portable recorders, including body-worn cameras and audio/video transmitters, emit radio waves that could trigger an explosive device. Therefore, these devices should not be used where an explosive device may be present.

Identification and Preservation of Recordings

To assist with identifying and preserving data and recordings, members should download, tag or mark the recordings in accordance with procedure and document the existence of the recording in any related case report.

A member should transfer, tag or mark recordings when the member reasonably believes:

- (a) The recording contains evidence relevant to potential criminal, civil or administrative matters.
- (b) A complainant, victim or witness has requested non-disclosure.
- (c) A complainant, victim or witness has not requested non-disclosure but the disclosure of the recording may endanger the person.
- (d) Disclosure may be an unreasonable violation of someone's privacy.
- (e) Medical or mental health information is contained.
- (f) Disclosure may compromise an under-cover officer or confidential informant.
- (g) The recording or portions of the recording may be protected under the Minnesota Data Practices Act.

Any time a member reasonably believes a recorded contact may be beneficial in a non-criminal matter (e.g., a hostile contact), the member should promptly notify a supervisor of the existence of the recording.

Review of Recorded Media Files

When preparing written reports, members should review their recordings as a resource (see the Officer-Involved Shootings and Deaths Policy for guidance in those cases). However, members shall not retain personal copies of recordings. Members should not use the fact that a recording was made as a reason to write a less detailed report.

Supervisors are authorized to review relevant recordings any time they are investigating alleged misconduct or reports of meritorious conduct or whenever such recordings would be beneficial in reviewing the member's performance.

Recorded files may also be reviewed:

- (a) By a supervisor as part of internal audits and reviews as required by Minn. Stat. § 626.8473.
- (b) Upon approval by a supervisor, by any member of the agency who is participating in an official investigation, such as a personnel complaint, administrative investigation, or criminal investigation.
- (c) Pursuant to lawful process or by court personnel who are otherwise authorized to review evidence in a related case.
- (d) By media personnel with permission of the Chief of Police or the authorized designee.
- (e) In compliance with the Minnesota Data Practices Act request, if permitted or required by the Act, including pursuant to Minn. Stat. § 13.82, Subd. 15, and in accordance with the Records Maintenance and Release Policy.

All recordings should be reviewed by a Custodian of Records prior to public release (see the Records Maintenance and Release Policy). Recordings that are clearly offensive to common sensibilities should not be publicly released unless disclosure is required by law or order of the court (Minn. Stat. § 13.82, Subd. 7; Minn. Stat. § 13.825, Subd. 2).

Coordinator

The Chief or the authorized designee should designate a coordinator responsible for (Minn. Stat.

§ 626.8473; Minn. Stat. § 13.825):

- (a) Establishing procedures for the security, storage and maintenance of data and recordings.
- (b) The coordinator should work with the Custodian of Records and the member assigned to coordinate the use, access and release of protected information to ensure that procedures comply with requirements of the Minnesota Government Data Practices Act (MGDPA) and other applicable laws (Minn. Stat. § 13.01 et seq.) (See the Protected Information and the Records Maintenance and Release policies).
- (c) The coordinator should work with the Custodian of Records to identify recordings that must be retained for a specific time frame under Minnesota law (e.g., firearm discharges, certain use of force incidents, formal complaints).
- (d) Establishing procedures for accessing data and recordings.
 - (a) These procedures should include the process to obtain written authorization for access to non-public data by MPD members and members of other governmental entities and agencies.

- (e) Establishing procedures for logging or auditing access.
- (f) Establishing procedures for transferring, downloading, tagging or marking events.
- (g) Establishing an inventory of portable recorders including:
 1. Total number of devices owned or maintained by the Menahga Police Department.
 2. Daily record of the total number deployed and used by members and, if applicable, the precinct or district in which the devices were used.
 3. Total amount of recorded audio and video data collected by the devices and maintained by the Menahga Police Department.
- (h) Preparing the biennial audit required by Minn. Stat. § 13.825, Subd. 9.
- (i) Notifying the Bureau of Criminal Apprehension (BCA) in a timely manner when new equipment is obtained by the Menahga Police Department that expands the type or scope of surveillance capabilities of the office's portable recorders.
- (j) Ensuring that this Portable Audio/Video Recorders Policy is posted on the agency website.

Prohibited Use of Audio/Video Recorders

Members are prohibited from using city-issued portable recorders and recording media for personal use and are prohibited from making personal copies of recordings created while on-duty or while acting in their official capacity.

Members are also prohibited from retaining recordings of activities or information obtained while on-duty. Members shall not duplicate or distribute such recordings, except for authorized legitimate agency business purposes. All such recordings shall be retained at the agency.

Members are prohibited from using personally owned recording devices while on-duty, Minn. Stat. § 13.825 Subd. 6.

Members are prohibited from activating the portable audio/video recorder to record their supervisors, other members, or other co-workers while in the confines of any City of Menahga facilities. Unless for training purposes only.

Recordings shall not be used by any member for the purpose of embarrassment, harassment or ridicule.

Retention of Recordings

All recordings shall be retained for a period consistent with the

requirements of the organization's records retention schedule but in no event for a period less than 90 days for not active or inactive criminal investigations, additionally, no less than one year for all other portable recording data. The agency will follow the retention of data outlined in Minn. Stat. § 13.825, Subd. 3.

If an individual captured in a recording submits a written request, the recording shall be retained for additional time period, up to 180 days. The coordinator should be responsible for notifying the individual prior to destruction of the recording (Minn. Stat. § 13.825 Subd. 3 (2) (c)).

Release of Audio/Video Recordings

Requests for the release of audio/video recordings shall be processed in accordance with the Records Maintenance and Release Policy.

Access to Recordings

Except as provided by Minn. Stat. § 13.825, Subd. 2, audio/video recordings are considered private or nonpublic data.

Any person captured in a recording may have access to the recording. If the individual requests a copy of the recording and does not have the consent of other non-law enforcement individuals captured on the recording, the identity of those individuals must be blurred or obscured sufficiently to render the subject unidentifiable prior to release. The identity of on-duty peace officers may not be obscured unless their identity is protected under Minn. Stat. § 13.82, Subd. 17.

Accountability

Any member who accesses or releases recordings without authorization may be subject to discipline (see the Standards of Conduct and the Protected Information policies) (Minn. Stat. § 626.8473).



MENAHA

Police Department

115 2ND Street NE
Menahga, MN 56464
PH:218.564.4516

Body-Worn/In Squad Pre-Shift Testing

Each member assigned a patrol car with a Watchguard system installed shall ensure it is operational at the beginning of each shift by the following procedure:

- Ensure you are logged into the camera system
- Ensure your Vista camera is/was docked and synced to the squad system
- Initiate a recording and ensure both camera systems activate upon initiation
 - If successful, stop the recording and label as Test/Delete
 - If unsuccessful, first try to dock the Vista for approximately one minute before trying again.
 - If still unsuccessful, notify a supervisor.
- Prior to the end of your shift, ensure all videos have the proper label on them. This can be accomplished in the Evidence Library System.

Category	Retention
Test/Delete	90 Days
Motorist Assist	90 Days
Civil Process	90 Days
Traffic Warning	90 Days
Emergency Operation	90 Days
Other/Non Traffic	90 Days
Assist Other Agency	90 Days
Suspicious Vehicle/Behavior	180 Days
Mental Health Assist	180 Days
Traffic Citation	365 Days
Arrest	365 Days
DWI	365 Days
Pursuit	365 Days
Interview	365 Days
Videos due are purged every Sunday	
Current as of 02/27/23	

Departmental Work Session Report

Department: Public Works

Date: 8/28/2023

	Comments	Next Steps/Due Date(s)
Informational	<ul style="list-style-type: none">• Finishing touches being done on Water Tower Paint.• Department of Health report on PFAS.• For Michaels run, gate will be unlocked and open South side of Cemetery.	
Financial	<ul style="list-style-type: none">• Payloader Tires	
Ongoing Items/Status Updates		
Action Items	<ul style="list-style-type: none">•	
Other		

memo

DATE: 7/27/23
TO: Menahga
FROM: Steve Robertson
Supervisor, Source Water Protection Unit
SUBJECT: Statewide Perfluoroalkyl Substances (PFAS) Monitoring Project

Below please find your system's sampling results for the Statewide PFAS Monitoring Project. Sampling was conducted on 12/20/2022.

Sampling results

There were no PFAS compounds detected in the samples. No additional action is needed at this time.

About the project

The Minnesota Department of Health (MDH) has been studying the potential health impacts of PFAS in groundwater in Minnesota since 2002. This project is part of a larger effort at MDH to sample all community water systems (CWSs) for PFAS. MDH aims to cover 90% of CWS customers under its PFAS monitoring program by 2025. The project has been made possible through funding from the Clean Water Fund and U.S. Environmental Protection Agency. Sampling results from all systems that participated in the study will be included in an interactive mapping application on the MDH website.

- For more information about the PFAS monitoring in Minnesota, please visit [PFAS Testing of Public Water Systems](https://www.health.state.mn.us/communities/environment/water/pfas.html) (<https://www.health.state.mn.us/communities/environment/water/pfas.html>).
- For more information about Phase I of this project, see the infosheet [Statewide PFAS Monitoring Project \(PDF\)](https://www.health.state.mn.us/communities/environment/water/docs/statewidepfas.pdf) (<https://www.health.state.mn.us/communities/environment/water/docs/statewidepfas.pdf>).

If you have any questions about the results, please contact Jane de Lambert, the Project Manager, at (651)201-4692.

cc: Jenny Soltys, MDH District Engineer
Attachment

PFAS RESULTS MEMO

St. Paul, MN 55164-0975
651-201-4700
health.drinkingwater@state.mn.us
www.health.state.mn.us

7/27/23

To obtain this information in a different format, call: 651-201-4700.

City of Menahga
"The Gateway to the Pines"



115 2nd Street NE
PO Box C
Menahga, MN 56464
218-564-4557
www.cityofmenahga.com

12-12-22

Dear City of Menahga U. S. Mail Recipient,

The Menahga City Council at their Regularly Scheduled Council Meeting held on December 12, 2022, approved the Adoption of The State of Minnesota Detailed Drawing of a Mailbox Support Standard, effective immediately. The need for this action stems from damages that may occur during snow removal. MN. Statute 169.072 (Subd.1), requires that any mailbox installed on a public highway must meet breakaway and location standards.

We ask that anyone that is wishing to have their mail delivered to a private mailbox which is placed on a public street, that the mailbox be installed using the attached MNDOT guidelines for MAILBOX SUPPORT (Swing-Away Type).

We realize that having this type of mailbox installed in winter could be difficult, so a temporary method for new mailbox customers will be allowed until June of 2023. A process for existing mailboxes will follow with a notice from the City of Menahga.

Thank you for your understanding,

A handwritten signature in black ink that reads "Jensine Kurtti". The signature is written in a cursive, flowing style.

Jensine Kurtti

Administrative Assistant

169.072 UNAUTHORIZED MAILBOX INSTALLATION.

Subdivision 1. **Public hazard.** A mailbox installation or support on a public highway that does not meet the breakaway and location standards contained in rules adopted under subdivision 2 is declared to be a public nuisance, a road hazard, and a danger to the health and safety of the traveling public.

Subd. 2. **Standards; rulemaking.** The commissioner shall by January 1, 1993, adopt rules that provide for standards and permissible locations of mailbox installations and supports on a street or highway. The commissioner shall base the rules substantially on federal highway administration regulations or recommendations, or other national standards or recommendations regarding the location and construction of safe, breakaway mailbox installations or supports. In adopting the rules, the commissioner shall consider the safety of the traveling public relative to the convenience and expense of owners of nonconforming mailbox installations or supports. The commissioner may provide for alternative standards to allow variances from the rules.

Subd. 3. **Removal, notice.** (a) After adoption of the rules authorized under subdivision 2, the commissioner or a road authority as defined in section 160.02, subdivision 25, may remove and replace a mailbox installation or support that is (1) located on a street or highway under the jurisdiction of the commissioner or road authority, and (2) does not conform to the rules adopted under subdivision 2. The commissioner or road authority may remove and replace a nonconforming mailbox installation or support not less than 60 days after giving notice, by personal notice or certified mail to the owner or the resident at the address served by the mailbox, of its intent to remove and replace the installation or support. The commissioner or road authority may charge the owner or resident not more than \$75 for the cost of the removal and replacement.

(b) The notice must at a minimum:

- (1) inform the owner of the nonconforming installation or support;
- (2) inform the owner or resident of the applicable law and rules, including the rules that contain the standards for mailbox installations and supports on public streets and highways;
- (3) inform the owner or resident that the owner or resident must remove the installation or support or bring it into compliance with the rules within 60 days of the date of the notice;
- (4) inform the owner or resident of the applicable laws and rules and the standards for mailbox installations and supports on public streets and highways, and provide plans or diagrams of examples of conforming installations or supports;
- (5) inform the owner or resident that if the nonconforming installation or support is not removed or replaced within 60 days of the date of the notice, the commissioner or road authority may remove and replace the installation or support at a cost of up to \$75 to the owner or resident; and
- (6) inform the owner or resident that where the replacement is made in conjunction with certain federally aided highway construction projects the replacement may be made at partial or no cost to the owner or resident.

History: 1991 c 339 s 6

8818.0300 PROHIBITED MAILBOX STRUCTURES; EXCEPTIONS.

Subpart 1. Unlawful installations and supports. The following mailbox installations and supports are declared to be a public nuisance, a road hazard, and a danger to the health and safety of the traveling public if located along a street or highway having a speed limit of 40 miles per hour or greater:

- A. an installation that contains more than one vertical support;
- B. a single support containing more than two mailboxes;
- C. a wooden support with a cross-sectional area greater than 16 square inches at any above-ground point along the support (for example, the maximum allowable square and round support dimensions are four inches by four inches and 4.5 inches in diameter, respectively), except that larger wooden supports are acceptable if, at a height four inches above the ground, the support cross-sectional area is altered in some fashion so as to reduce the cross-sectional area at that point to 16 square inches or less;
- D. a metal support of a weight of four pounds per foot or more for any one foot of vertical measurement above ground (for example, a standard steel pipe of up to two inches inner diameter would be acceptable), except that larger metal supports are acceptable if, within the first three inches above ground the metal support is less than four pounds per foot (less than one pound for the three-inch length);
- E. a mailbox that is not acceptable for delivery of mail by the United States Postal Service;
- F. adjacent mailbox installations whose respective supports are spaced closer than 30 inches, as measured from center of support to center of support;
- G. neighborhood delivery and collection box units, whether or not United States Postal Service approved;
- H. a support comprised of material other than solely wood or metal that either exceeds 16 square inches in total cross-sectional area at a height four inches above ground or is of a weight of four pounds per foot or more for any one foot of vertical measurement above ground, unless within the first three inches above ground the support is less than four pounds per foot (less than one pound over the three-inch distance). Examples of such nonconforming supports could include supports such as filled milk cans, brick structures, plows, and concrete-filled pipe; and
- I. an installation, whether a support or closed mailbox, that encroaches the usable roadway or its airspace.

Subp. 2. Exceptions. Notwithstanding subpart 1, mailbox installations that are documented to have passed an accredited crash test are acceptable. An accredited crash test is considered to be a test conducted in accordance with procedures described in the

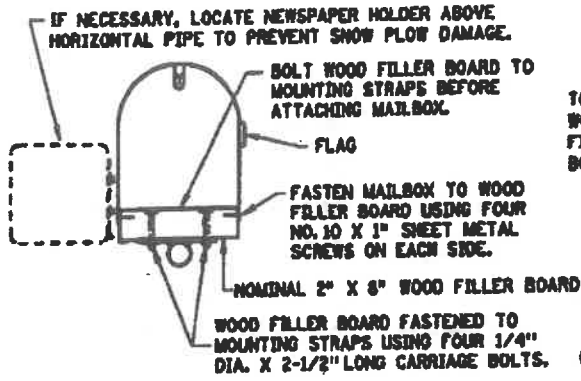

SECTION A-A

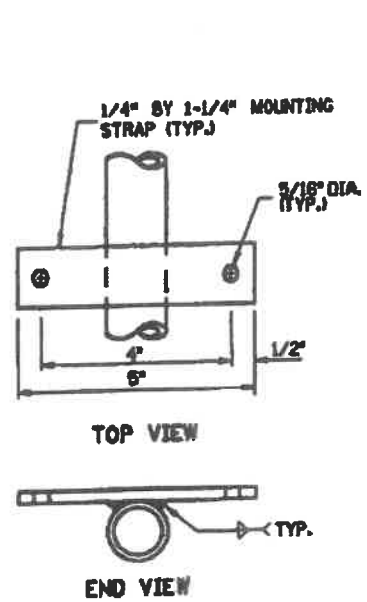

MOUNTING STRAP DETAIL

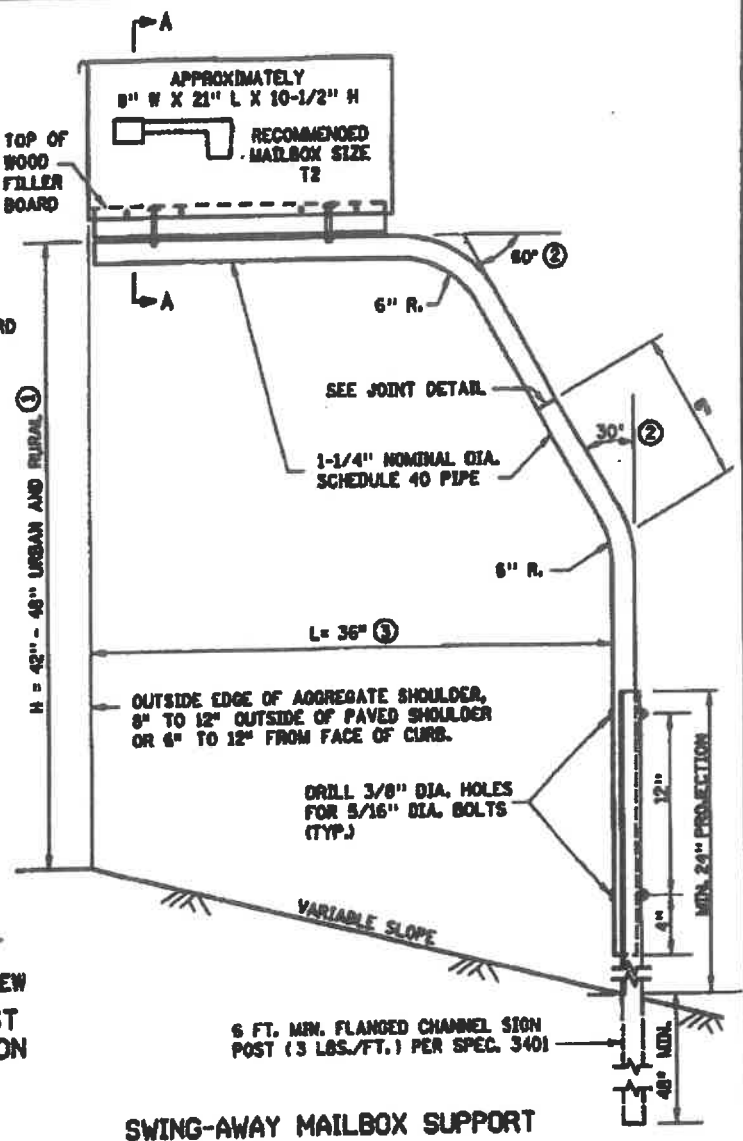

SWING-AWAY MAILBOX SUPPORT

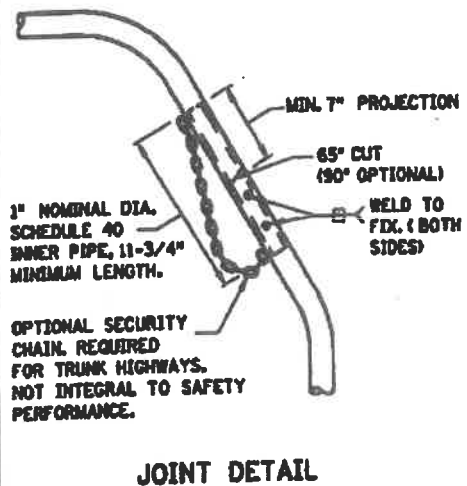

JOINT DETAIL

- NOTES:**
- MAILBOX LOCATIONS SHOULD BE STAKED BEFORE INSTALLATION FOR PROPER HEIGHT AND DISTANCE FROM THE ROADWAY. ONCE STAKED, THE INSTALLER MUST NOTIFY THE ENGINEER AND THE POST OFFICE. THE ENGINEER AND THE POSTMASTER SHALL APPROVE THE STAKED LOCATIONS PRIOR TO FINAL INSTALLATION.
 - THE MINIMUM SPACING (CENTER TO CENTER BETWEEN MULTIPLE MAILBOX SUPPORTS) SHALL BE EQUAL TO THE HEIGHT OF THE MAILBOX SUPPORT.
 - OTHER MAILBOX SUPPORT DESIGNS MAY BE USED IF THEY SATISFY NCHRP REPORT 350 CRITERIA IN ACCORDANCE WITH FHWA ACCEPTANCE LETTER, MEET MINNESOTA RULES 8816 AND U.S. POST OFFICE RECOMMENDATIONS AND ARE IN COMPLIANCE WITH MN/DOT REQUIREMENTS WHICH MAY INCLUDE THE FOLLOWING (REQUIRED ON TRUNK HIGHWAYS):
 - PIPE SHALL CONFORM TO SPEC. 3362, SCHEDULE 40 OF ASTM A53/A53M.
 - ALL FASTENERS SHALL CONFORM TO SPEC. 3391.
 - PIPES, POST AND OTHER STEEL COMPONENTS SHALL BE GALVANIZED PER SPEC. 3392.
 - THE CONTRACTOR SHALL SEND THE SHOP DRAWINGS TO THE ENGINEER FOR APPROVAL. FOR QUESTIONS REGARDING DESIGN ELEMENTS AND BREAKAWAY FEATURES, CONTACT THE DESIGN STANDARDS UNIT.
 - ① ANY CHANGE IN HEIGHT OR MUST BE APPROVED BY LOCAL POSTMASTER.
 - ② 45° BENDS MAY BE USED AS AN OPTION.
 - ③ A 48° OR 53° CANTILEVER LENGTH (L) MAY BE USED AS AN OPTION FOR NON-TRUNK HIGHWAY USE.

APPROVED <u> JUNE 1, 2007 </u> STATE DESIGN ENGINEER	STATE OF MINNESOTA DEPARTMENT OF TRANSPORTATION MAILBOX SUPPORT SWING-AWAY TYPE	SPECIFICATION REFERENCE 3362 3391 3392 3401	STANDARD PLATE NO. 9350A
---	---	--	--

most recent National Cooperative Highway Research Program report, "Recommended Procedures for the Safety Performance Evaluation of Highway Appurtenances," published by the Transportation Research Board, National Academy of Sciences, 2101 Constitution Avenue N.W., Washington, D.C. 20418. This report and future revisions of this report are incorporated by reference. The report is not subject to frequent change and is available to the public at the State Law Library, Judicial Center, 25 Rev. Dr. Martin Luther King Jr. Blvd., St. Paul, Minnesota 55155, and through the Minitex interlibrary loan system.

Statutory Authority: *MS s 169.072*

History: *19 SR 344*

Published Electronically: *January 31, 2000*

ESTIMATE

Steve's Tire Service LLC
19139 Easy Drive
Park Rapids, MN 56470

stevestireservice@yahoo.com
+1 (218) 252-0715

City Of Menahga

Bill to
City Of Menahga

Estimate details

Estimate no.: 1002
Estimate date: 08/22/2023

	Product or service	Amount
1.	Tires 20.5 25 Bridgestone VSWAS State Bid Price	\$9,965.40
2.	Tires 20.5 25 Nokian Hakka	\$10,320.00
3.	Services 20.5 25 Maxam MS 202	4 x \$2,085.00 \$8,340.00
4.	Labor Labor for Dismount/Mount on rim And on And off the machine	\$1,600.00
	Total	\$30,225.40

CITY OF MENAHGA
***Budget YTD Rev-Exp©**

08/24/23 3:19 PM
Page 40

Current Period: July 2023

		2023	2023	July	2023	% of
		YTD Budget	YTD Amt	MTD Amt	YTD Balance	Budget
MUNICIPAL LIQUOR FUND						
	Revenues	\$1,237,415.60	\$705,427.33	\$147,885.98	\$531,988.27	57.01%
	Expenditures	\$1,043,324.00	\$638,981.20	\$141,026.48	\$404,342.80	61.24%
	Gain/(Loss)	\$194,091.60	\$66,446.13	\$6,859.50	\$127,645.47	34.23%
Miscellaneous						
Active	R 609-00000-36238 Dividends/Patr	\$0.00	\$533.31	\$0.00	(\$533.31)	0.00%
Active	R 609-00000-37840 Cash Over/Un	\$0.00	\$46.00	\$0.00	(\$46.00)	0.00%
	Revenue	\$0.00	\$579.31	\$0.00	(\$579.31)	0.00%
	Total Miscellaneous	\$0.00	\$579.31	\$0.00	(\$579.31)	0.00%
Liquor Store Off-Sale						
Active	R 609-49750-31300 General Sales	\$102,765.60	\$0.00	\$0.00	\$102,765.60	0.00%
Active	R 609-49750-31500 Sales	\$0.00	\$0.00	\$0.00	\$0.00	0.00%
Active	R 609-49750-34954 Lions Lease P	\$0.00	\$450.00	\$450.00	(\$450.00)	0.00%
Active	R 609-49750-34955 Miscellaneous	\$0.00	\$0.00	\$0.00	\$0.00	0.00%
Active	R 609-49750-34957 Apparel Sales	\$0.00	\$862.00	\$240.00	(\$862.00)	0.00%
Active	R 609-49750-36200 Interest Earnin	\$0.00	\$1,132.41	\$101.93	(\$1,132.41)	0.00%
Active	R 609-49750-36213 Ameritrade Net	\$0.00	\$0.00	\$0.00	\$0.00	0.00%
Active	R 609-49750-36214 Ameritrade Divi	\$0.00	\$0.00	\$0.00	\$0.00	0.00%
Active	R 609-49750-36235 Refunds & Rei	\$125.00	\$0.00	\$0.00	\$125.00	0.00%
Active	R 609-49750-37811 Liquor Sales - (\$235,000.00	\$140,620.75	\$27,107.71	\$94,379.25	59.84%
Active	R 609-49750-37812 Beer Sales - (\$500,000.00	\$322,083.19	\$71,921.73	\$177,916.81	64.42%
Active	R 609-49750-37813 Wine Sales - (\$43,000.00	\$18,821.50	\$3,496.92	\$24,178.50	43.77%
Active	R 609-49750-37815 Tobacco Sales	\$8,000.00	\$6,539.20	\$1,391.10	\$1,460.80	81.74%
Active	R 609-49750-37816 Snack, Ice, So	\$20,000.00	\$16,494.67	\$4,776.03	\$3,505.33	82.47%
Active	R 609-49750-37817 Bar Transfer	\$0.00	\$0.00	\$0.00	\$0.00	0.00%
Active	R 609-49750-37820 Credit Card Sal	\$0.00	\$0.00	\$0.00	\$0.00	0.00%
Active	R 609-49750-37840 Cash Over/Un	\$0.00	(\$42.63)	(\$15.78)	\$42.63	0.00%
Active	R 609-49750-39101 Sales of Gener	\$0.00	\$0.00	\$0.00	\$0.00	0.00%
Active	R 609-49750-39102 Compensation-	\$0.00	\$0.00	\$0.00	\$0.00	0.00%
Active	R 609-49750-99000 Transfer In	\$0.00	\$0.00	\$0.00	\$0.00	0.00%
	Revenue	\$908,890.60	\$506,961.09	\$109,469.64	\$401,929.51	55.78%
Active	E 609-49750-101 Salaries	\$70,492.00	\$34,994.07	\$4,806.73	\$35,497.93	49.64%
Active	E 609-49750-103 Part-time Salaries	\$5,131.00	\$4,846.89	\$1,264.68	\$284.11	94.46%
Active	E 609-49750-104 Admin Salaries	\$1,195.00	\$0.00	\$0.00	\$1,195.00	0.00%
Active	E 609-49750-105 Unemployment	\$0.00	\$0.00	\$0.00	\$0.00	0.00%
Active	E 609-49750-121 PERA	\$5,761.00	\$2,580.19	\$360.48	\$3,180.81	44.79%
Active	E 609-49750-122 Social Security	\$4,762.00	\$2,458.04	\$374.64	\$2,303.96	51.62%
Active	E 609-49750-128 Medicare	\$1,114.00	\$574.94	\$87.64	\$539.06	51.61%
Active	E 609-49750-131 Employer Paid H	\$12,846.00	\$5,213.04	\$744.72	\$7,632.96	40.58%
Active	E 609-49750-132 Employer Paid H	\$3,500.00	\$2,639.87	\$1,312.50	\$860.13	75.42%
Active	E 609-49750-134 Employer Paid Lif	\$45.00	\$63.00	\$9.00	(\$18.00)	140.00%
Active	E 609-49750-135 Employer Paid A	\$0.00	\$0.00	\$0.00	\$0.00	0.00%
Active	E 609-49750-136 Employer Paid D	\$0.00	\$195.42	\$28.81	(\$195.42)	0.00%
Active	E 609-49750-155 Sales Tax	\$0.00	\$115.27	\$0.00	(\$115.27)	0.00%
Active	E 609-49750-200 Office Supplies	\$153.00	\$110.94	\$110.94	\$42.06	72.51%
Active	E 609-49750-210 Operating Supplie	\$8,377.00	\$1,819.53	\$339.15	\$6,557.47	21.72%
Active	E 609-49750-215 Entertainment	\$0.00	\$0.00	\$0.00	\$0.00	0.00%
Active	E 609-49750-217 Uniform Allowanc	\$0.00	\$126.00	\$49.50	(\$126.00)	0.00%
Active	E 609-49750-220 Repair & Mainten	\$2,295.00	\$0.00	\$0.00	\$2,295.00	0.00%
Active	E 609-49750-250 Merchandise Res	\$0.00	\$1,325.50	\$418.50	(\$1,325.50)	0.00%

CITY OF MENA HGA
***Budget YTD Rev-Exp©**

08/24/23 3:19 PM
Page 41

Current Period: July 2023

		2023	2023	July	2023	% of	
		YTD Budget	YTD Amt	MTD Amt	YTD Balance	Budget	
Active	E 609-49750-251	Liquor Purchases	\$202,183.00	\$121,353.52	\$34,412.72	\$80,829.48	60.02%
Active	E 609-49750-252	Beer Purchases	\$394,168.00	\$238,051.55	\$59,238.78	\$156,116.45	60.39%
Active	E 609-49750-254	Snack, Ice, Soda	\$14,473.00	\$10,603.55	\$3,464.49	\$3,869.45	73.26%
Active	E 609-49750-256	Tobacco Product	\$5,848.00	\$4,916.34	\$1,164.48	\$931.66	84.07%
Active	E 609-49750-260	Credit Card Fees	\$843.00	\$6,686.85	\$1,247.50	(\$5,843.85)	793.22%
Active	E 609-49750-301	Auditing Services	\$5,500.00	\$0.00	\$0.00	\$5,500.00	0.00%
Active	E 609-49750-304	Legal Services	\$2,783.00	\$0.00	\$0.00	\$2,783.00	0.00%
Active	E 609-49750-305	Professional Serv	\$785.00	\$303.86	\$33.49	\$481.14	38.71%
Active	E 609-49750-309	Computer Suppor	\$1,212.00	\$231.17	\$0.00	\$980.83	19.07%
Active	E 609-49750-321	Telephone/Fax/In	\$950.00	\$588.00	\$86.15	\$362.00	61.89%
Active	E 609-49750-331	Travel & Confere	\$0.00	\$30.14	\$30.14	(\$30.14)	0.00%
Active	E 609-49750-333	Freight	\$4,082.00	\$2,581.90	\$749.54	\$1,500.10	63.25%
Active	E 609-49750-340	Advertising	\$850.00	\$274.00	\$25.00	\$576.00	32.24%
Active	E 609-49750-350	Printing & Publish	\$0.00	\$0.00	\$0.00	\$0.00	0.00%
Active	E 609-49750-361	General Liability I	\$480.00	\$358.84	\$358.84	\$121.16	74.76%
Active	E 609-49750-362	Property Insuranc	\$1,649.00	\$1,315.00	\$1,315.00	\$334.00	79.75%
Active	E 609-49750-364	Dram Shop Insur	\$2,840.00	\$1,937.00	\$0.00	\$903.00	68.20%
Active	E 609-49750-365	Errors & Omissio	\$297.00	\$242.66	\$242.66	\$54.34	81.70%
Active	E 609-49750-367	Workers Compen	\$4,862.00	\$3,496.78	\$0.00	\$1,365.22	71.92%
Active	E 609-49750-381	Electric Utilities	\$7,897.00	\$4,835.45	\$759.49	\$3,061.55	61.23%
Active	E 609-49750-382	Water/Sewer Utili	\$446.00	\$547.61	\$63.43	(\$101.61)	122.78%
Active	E 609-49750-383	Gas Utilities	\$977.00	\$734.39	\$32.09	\$242.61	75.17%
Active	E 609-49750-384	Garbage Services	\$1,290.00	\$977.29	\$77.50	\$312.71	75.76%
Active	E 609-49750-385	Cable Utilities	\$447.00	\$0.00	\$0.00	\$447.00	0.00%
Active	E 609-49750-386	Cleaning Service	\$1,746.00	\$755.00	\$0.00	\$991.00	43.24%
Active	E 609-49750-419	Equipment Lease	\$1,391.00	\$1,305.51	\$174.61	\$85.49	93.85%
Active	E 609-49750-420	Depreciation Exp	\$0.00	\$0.00	\$0.00	\$0.00	0.00%
Active	E 609-49750-430	Miscellaneous Ex	\$4,341.00	\$0.00	\$0.00	\$4,341.00	0.00%
Active	E 609-49750-431	Cash Short	\$0.00	\$0.00	\$0.00	\$0.00	0.00%
Active	E 609-49750-433	Dues and Subscri	\$700.00	\$25.00	\$0.00	\$675.00	3.57%
Active	E 609-49750-437	Licenses & Permi	\$270.00	\$0.00	\$0.00	\$270.00	0.00%
Active	E 609-49750-440	Bad Debt Expens	\$0.00	\$0.00	\$0.00	\$0.00	0.00%
Active	E 609-49750-500	Capital Outlay	\$0.00	\$0.00	\$0.00	\$0.00	0.00%
Active	E 609-49750-600	Principal	\$0.00	\$0.00	\$0.00	\$0.00	0.00%
Active	E 609-49750-610	Interest	\$0.00	\$0.00	\$0.00	\$0.00	0.00%
Active	E 609-49750-990	Transfer Out	\$0.00	\$0.00	\$0.00	\$0.00	0.00%
Active	E 609-49750-999	CoVid-19	\$0.00	\$0.00	\$0.00	\$0.00	0.00%
Expenditure			<u>\$778,981.00</u>	<u>\$459,214.11</u>	<u>\$113,383.20</u>	<u>\$319,766.89</u>	<u>58.95%</u>
Total Liquor Store Off-Sale			\$129,909.60	\$47,746.98	(\$3,913.56)	\$82,162.62	36.75%
Liquor Store On-Sale							
Active	R 609-49760-31500	Sales	\$0.00	\$0.00	\$0.00	\$0.00	0.00%
Active	R 609-49760-34954	Lions Lease P	\$1,800.00	\$900.00	\$0.00	\$900.00	50.00%
Active	R 609-49760-34955	Miscellaneous	\$200.00	\$431.65	\$0.00	(\$231.65)	215.83%
Active	R 609-49760-34957	Apparel Sales	\$300.00	\$2,261.00	\$596.00	(\$1,961.00)	753.67%
Active	R 609-49760-36200	Interest Earnin	\$0.00	\$353.83	\$0.00	(\$353.83)	0.00%
Active	R 609-49760-36212	ATM User Fee	\$2,000.00	\$1,000.50	\$217.50	\$999.50	50.03%
Active	R 609-49760-36213	Ameritrade Net	\$0.00	\$0.00	\$0.00	\$0.00	0.00%
Active	R 609-49760-36214	Ameritrade Divi	\$0.00	\$0.00	\$0.00	\$0.00	0.00%
Active	R 609-49760-36235	Refunds & Rei	\$125.00	\$0.00	\$0.00	\$125.00	0.00%
Active	R 609-49760-37820	Credit Card Sal	\$0.00	\$0.00	\$0.00	\$0.00	0.00%
Active	R 609-49760-37840	Cash Over/Un	\$300.00	(\$36.20)	\$56.93	\$336.20	-12.07%
Active	R 609-49760-37911	Liquor Sales - (\$140,000.00	\$82,867.54	\$17,957.22	\$57,132.46	59.19%

CITY OF MENAHGA
***Budget YTD Rev-Exp©**

08/24/23 3:19 PM

Page 42

Current Period: July 2023

			2023	2023	July	2023	% of
			YTD Budget	YTD Amt	MTD Amt	YTD Balance	Budget
Active	R 609-49760-37912	Beer Sales - (\$150,000.00	\$89,794.40	\$16,587.80	\$60,205.60	59.86%
Active	R 609-49760-37915	Tobacco Sales	\$2,000.00	\$1,609.00	\$167.00	\$391.00	80.45%
Active	R 609-49760-37916	Snack, Ice, So	\$30,000.00	\$17,546.46	\$2,943.89	\$12,453.54	58.49%
Active	R 609-49760-37920	Vending Machi	\$1,800.00	\$1,158.75	(\$110.00)	\$641.25	64.38%
Active	R 609-49760-39101	Sales of Gener	\$0.00	\$0.00	\$0.00	\$0.00	0.00%
Active	R 609-49760-39102	Compensation-	\$0.00	\$0.00	\$0.00	\$0.00	0.00%
Active	R 609-49760-99000	Transfer In	\$0.00	\$0.00	\$0.00	\$0.00	0.00%
	Revenue		\$328,525.00	\$197,886.93	\$38,416.34	\$130,638.07	60.23%
Active	E 609-49760-101	Salaries	\$70,492.00	\$35,239.75	\$4,806.66	\$35,252.25	49.99%
Active	E 609-49760-103	Part-time Salaries	\$5,131.00	\$4,846.74	\$1,264.65	\$284.26	94.46%
Active	E 609-49760-104	Admin Salaries	\$1,195.00	\$0.00	\$0.00	\$1,195.00	0.00%
Active	E 609-49760-105	Unemployment	\$0.00	\$0.00	\$0.00	\$0.00	0.00%
Active	E 609-49760-121	PERA	\$5,761.00	\$2,580.22	\$360.53	\$3,180.78	44.79%
Active	E 609-49760-122	Social Security	\$4,762.00	\$2,457.93	\$374.64	\$2,304.07	51.62%
Active	E 609-49760-128	Medicare	\$1,114.00	\$574.73	\$87.58	\$539.27	51.59%
Active	E 609-49760-131	Employer Paid H	\$13,380.00	\$5,213.04	\$744.72	\$8,166.96	38.96%
Active	E 609-49760-132	Employer Paid H	\$4,292.00	\$2,639.88	\$1,312.50	\$1,652.12	61.51%
Active	E 609-49760-134	Employer Paid Lif	\$45.00	\$63.00	\$9.00	(\$18.00)	140.00%
Active	E 609-49760-136	Employer Paid D	\$0.00	\$195.51	\$28.82	(\$195.51)	0.00%
Active	E 609-49760-155	Sales Tax	\$55.00	\$81.40	\$0.00	(\$26.40)	148.00%
Active	E 609-49760-200	Office Supplies	\$62.00	\$110.94	\$110.94	(\$48.94)	178.94%
Active	E 609-49760-210	Operating Supplie	\$5,964.00	\$7,599.84	\$1,953.82	(\$1,635.84)	127.43%
Active	E 609-49760-215	Entertainment	\$10,000.00	\$8,280.00	\$280.00	\$1,720.00	82.80%
Active	E 609-49760-217	Uniform Allowanc	\$50.00	\$126.00	\$49.50	(\$76.00)	252.00%
Active	E 609-49760-220	Repair & Mainten	\$4,800.00	\$1,286.71	\$0.00	\$3,513.29	26.81%
Active	E 609-49760-250	Merchandise Res	\$295.00	\$1,061.50	\$418.50	(\$766.50)	359.83%
Active	E 609-49760-251	Liquor Purchases	\$21,443.00	\$17,111.38	\$3,008.78	\$4,331.62	79.80%
Active	E 609-49760-252	Beer Purchases	\$31,568.00	\$26,404.55	\$5,337.69	\$5,163.45	83.64%
Active	E 609-49760-254	Snack, Ice, Soda	\$21,064.00	\$14,247.87	\$2,475.85	\$6,816.13	67.64%
Active	E 609-49760-256	Tobacco Product	\$2,022.00	\$1,821.58	\$234.10	\$200.42	90.09%
Active	E 609-49760-260	Credit Card Fees	\$5,178.00	\$7,474.78	\$1,247.51	(\$2,296.78)	144.36%
Active	E 609-49760-301	Auditing Services	\$0.00	\$0.00	\$0.00	\$0.00	0.00%
Active	E 609-49760-304	Legal Services	\$0.00	\$0.00	\$0.00	\$0.00	0.00%
Active	E 609-49760-305	Professional Serv	\$956.00	\$393.62	\$85.25	\$562.38	41.17%
Active	E 609-49760-309	Computer Suppor	\$1,189.00	\$231.17	\$0.00	\$957.83	19.44%
Active	E 609-49760-321	Telephone/Fax/In	\$611.00	\$307.92	\$46.15	\$303.08	50.40%
Active	E 609-49760-331	Travel & Confere	\$0.00	\$30.12	\$30.12	(\$30.12)	0.00%
Active	E 609-49760-333	Freight	\$104.00	\$160.25	\$10.00	(\$56.25)	154.09%
Active	E 609-49760-340	Advertising	\$850.00	\$340.00	\$25.00	\$510.00	40.00%
Active	E 609-49760-350	Printing & Publish	\$92.00	\$0.00	\$0.00	\$92.00	0.00%
Active	E 609-49760-361	General Liability I	\$1,020.00	\$358.84	\$358.84	\$661.16	35.18%
Active	E 609-49760-362	Property Insuranc	\$1,649.00	\$1,315.00	\$1,315.00	\$334.00	79.75%
Active	E 609-49760-364	Dram Shop Insur	\$2,840.00	\$1,937.00	\$0.00	\$903.00	68.20%
Active	E 609-49760-365	Errors & Omissio	\$297.00	\$242.67	\$242.67	\$54.33	81.71%
Active	E 609-49760-367	Workers Compen	\$4,863.00	\$3,496.79	\$0.00	\$1,366.21	71.91%
Active	E 609-49760-381	Electric Utilities	\$7,897.00	\$4,835.46	\$759.49	\$3,061.54	61.23%
Active	E 609-49760-382	Water/Sewer Utili	\$561.00	\$547.61	\$63.44	\$13.39	97.61%
Active	E 609-49760-383	Gas Utilities	\$905.00	\$735.39	\$32.09	\$169.61	81.26%
Active	E 609-49760-384	Garbage Services	\$756.00	\$532.25	\$77.49	\$223.75	70.40%
Active	E 609-49760-385	Cable Utilities	\$1,135.00	\$1,101.59	\$147.33	\$33.41	97.06%
Active	E 609-49760-386	Cleaning Service	\$2,154.00	\$1,775.00	\$170.00	\$379.00	82.40%
Active	E 609-49760-419	Equipment Lease	\$2,110.00	\$1,305.49	\$174.62	\$804.51	61.87%

CITY OF MENA HGA
***Budget YTD Rev-Exp©**

Current Period: July 2023

			2023	2023	July	2023	% of
			YTD Budget	YTD Amt	MTD Amt	YTD Balance	Budget
Active	E 609-49760-430	Miscellaneous Ex	\$4,341.00	\$0.00	\$0.00	\$4,341.00	0.00%
Active	E 609-49760-431	Cash Short	\$0.00	\$0.00	\$0.00	\$0.00	0.00%
Active	E 609-49760-433	Dues and Subscri	\$700.00	\$25.00	\$0.00	\$675.00	3.57%
Active	E 609-49760-437	Licenses & Permi	\$640.00	\$403.75	\$0.00	\$236.25	63.09%
Active	E 609-49760-440	Bad Debt Expens	\$0.00	\$0.00	\$0.00	\$0.00	0.00%
Active	E 609-49760-500	Capital Outlay	\$20,000.00	\$20,274.82	\$0.00	(\$274.82)	101.37%
Active	E 609-49760-990	Transfer Out	\$0.00	\$0.00	\$0.00	\$0.00	0.00%
Active	E 609-49760-999	CoVid-19	\$0.00	\$0.00	\$0.00	\$0.00	0.00%
Expenditure			<u>\$264,343.00</u>	<u>\$179,767.09</u>	<u>\$27,643.28</u>	<u>\$84,575.91</u>	<u>68.01%</u>
Total Liquor Store On-Sale			<u>\$64,182.00</u>	<u>\$18,119.84</u>	<u>\$10,773.06</u>	<u>\$46,062.16</u>	<u>28.23%</u>
Total MUNICIPAL LIQUOR FUND			<u>\$194,091.60</u>	<u>\$66,446.13</u>	<u>\$6,859.50</u>	<u>\$127,645.47</u>	<u>34.23%</u>



Sebeka
 5 Hubbard Avenue
 Sebeka, MN 56477
 Ph 218.837.5547
 Email eravnaas@bergstromelectric.com

PROPOSAL

PROPOSAL SUBMITTED TO: City of Menahga		PHONE: 218-564-4557 8/11/2023
STREET: 115 2nd st NE		FAX: _____ Heat tape GFI and switch for heat tape above fire dept.
Menahga	STATE: MN ZIP: 56464	
EMAIL	PROPOSAL #: 77-1176 Ralph	PHONE #: _____

WE HEREBY SUBMIT CERTIFICATION AND ESTIMATE FOR:

- Work to include:**
- 2: GFI receptacles off of existing circuitry**
 - 2: Light switches inside in firehall**
 - 1: Misc material, labor**
 - 1: State electrical inspection fee**

We Propose - HEREBY FURNISH MATERIAL & LABOR, COMPLETE IN ACCORDANCE WITH ABOVE SPECIFICATIONS, FOR THE SUM OF: **\$950.00)**

PAYMENT TO BE MADE AS FOLLOWS:
Net ten days upon completion

All material is guaranteed to be as specified. All work to be completed in a workmanlike manner according to standard practices. Any alteration or deviation from above specifications involving extra costs will be executed only upon written orders, and will become an extra charge over and above the estimate. All agreements contingent upon strikes, accidents or delays beyond our control. Owner to carry fire, tornado, and necessary insurance. Our workers are fully covered by workers compensation insurance.

Eric Ravnaas

NOTE: THIS PROPOSAL MAY BE WITHDRAWN BY US IF NOT ACCEPTED WITHIN >>>>> **30** DAYS.

Acceptance of Proposal

THE ABOVE PRICES, SPECIFICATIONS AND CONDITIONS ARE SATISFACTORY AND ARE HEREBY ACCEPTED. YOU ARE AUTHORIZED TO DO THE WORK SPECIFIED. PAYMENT WILL BE MADE AS OUTLINED ABOVE.

SIGNATURE: _____

DATE: _____

Grand Forks
 3100 North Washington St.
 Grand Forks, ND 58203
 Ph 701.775.8897
 Fx 701.772.4951

Bismarck
 3554 East Divide Ave.
 Bismarck, ND 58501
 Ph 701.221.0783
 Fx 701.221.0784

Devils Lake
 1100 2nd Ave NE
 Devils Lake, ND 58301
 Ph 701.662.5823
 Fx 701.662.8996

Crookston
 302 North Main
 Crookston, MN 56716
 Ph 218.281.7571
 Fx 218.281.1911

Thief River Falls
 1402 3rd Street West
 Thief River Falls, MN 56701
 Ph 218.681.7422
 Fx 218.681.6288

Visit us on our website at www.bergstromelectric.com

Employee Owned - Where Quality & Customers Matter

CITY OF MENAHGA
***Check Reconciliation©**
MAIN RECON

08/24/23 1:27 PM

Page 1

JNST/10109 GEN CHKG/10120 RESDEBT/10103 GEN CHKG/10107 WELLHEADPR/10

July 2023

Account Summary

Beginning Balance on 7/1/2023	\$281,318.52
+ Receipts/Deposits	\$535,723.38
- Payments (Checks and Withdrawals)	\$443,327.67
Ending Balance as of 7/30/2023	\$373,714.23

Cleared	\$373,714.23
Statement	\$373,714.23
Difference	\$0.00

Cash Balance

Active 101-10100 GENERAL FUND	-\$271,301.95
Active 101-10102 GENERAL FUND	\$0.00
Active 101-10103 GENERAL FUND	\$0.00
Active 101-10104 GENERAL FUND	\$0.00
Active 101-10105 GENERAL FUND	\$0.00
Active 225-10100 SAFE ROUTES TO SCHOOL	-\$3,291.50
Active 226-10100 ECONOMIC DEV REVOLVING LN FD	\$41,672.30
Active 228-10100 TIF DISTRICT PEDRO	\$21,942.47
Active 233-10100 TIF DISTRICT 1-6 PLEASANT PINE	-\$9,007.40
Active 303-10100 1990 CITY HALL DEBT FUND	\$0.00
Active 304-10100 2012A FIRE TRUCK	-\$1,117.26
Active 304-10120 2012A FIRE TRUCK	\$0.00
Active 307-10100 WATER SEWER DEBT	\$12,140.45
Active 310-10100 2012a NURSING HOME DEBT FUND	\$24,936.38
Active 311-10100 2003 IMPROVEMENT DEBT FUND	\$0.00
Active 312-10100 2004 IMPROVEMENT DEBT FUND	\$0.00
Active 313-10100 2006 UTILITY/STREET IMPROV	\$0.00
Active 314-10100 SPECIAL PROJECT DEBT FUND	\$0.00
Active 315-10100 2009 GO IMPROVEMENT	\$0.00
Active 316-10100 2013 STREET & UTILITY IMPROVEM	\$255,482.76
Active 317-10100 2015B Imp. Refunding GO Bond	-\$84,267.16
Active 318-10100 2020A GO Improvement Refunding	-\$175,442.73
Active 404-10100 2009 CSAH 21	\$0.00
Active 406-10100 CAPITAL PROJECTS-EQUIPMENT	-\$46,035.26
Active 406-10102 CAPITAL PROJECTS-EQUIPMENT	\$0.00
Active 406-10104 CAPITAL PROJECTS-EQUIPMENT	\$0.00
Active 406-10105 CAPITAL PROJECTS-EQUIPMENT	\$65,294.47
Active 406-10109 CAPITAL PROJECTS-EQUIPMENT	\$0.00
Active 414-10100 2017 N.H. CONST-CAPITAL PROJ	\$0.00
Active 415-10100 2020a Bond	\$0.00
Active 416-10100 Region 5 Energy Initiative	\$16,451.21
Active 417-10100 Water Tower Construction	-\$33,432.31
Active 418-10100 TH87 Watermain Replacement	-\$20,283.00
Active 601-10100 WATER FUND	\$212,564.21
Active 601-10106 WATER FUND	\$0.00
Active 601-10107 WATER FUND	\$0.00
Active 601-10108 WATER FUND	\$0.00
Active 602-10100 SEWER FUND	\$84,028.31
Active 602-10106 SEWER FUND	\$0.00
Active 602-10108 SEWER FUND	\$0.00
Active 607-10100 CEMETERY FUND	\$19,911.46

Begining Balance	\$281,318.52
+ Total Deposits	\$535,723.38
- Checks Written	\$637,030.72
Check Book Balance	\$180,011.18
Difference	\$0.00

Active	609-10100 MUNICIPAL LIQUOR FUND	\$101,138.73
Active	750-10100 PAYROLL CLEARING FUND	-\$17,144.07
Active	755-10100 GET HOOKED ON FISHING	\$8,891.73
Active	760-10100 SOUNDS OF SPIRIT LAKE	\$6,806.54
Active	765-10100 BRE PROJECTS	\$4,679.52
Active	770-10100 Frisbee Golf	-\$373.36
Active	800-10100 American Rescue Plan	\$0.00
Active	999-10100 Covid 19-	-\$34,233.36
	Cash Balance	\$180,011.18

CITY OF MENAHGA

*Check Reconciliation©

GENERAL CHECKING

10100 GEN CHECK

Check Nbr	Vendor Name	Check Date	Amount	Cleared This Month	Amount Not Cleared	Partially Cleared Last Month
Deposit	20230614UB2	6/14/2023	\$0.00	-	-	-
Deposit	070323 AllPaid	7/3/2023	(\$975.40)	(\$975.40)	-	-
Deposit	20230811UB2	7/5/2023	(\$66.69)	(\$66.69)	-	-
Deposit	070723FireCall	7/7/2023	(\$500.00)	(\$500.00)	-	-
Deposit	070723 GPA Special	7/7/2023	(\$1,780.00)	(\$1,780.00)	-	-
Deposit	071123 LS Change	7/11/2023	(\$3,000.00)	(\$3,000.00)	-	-
Deposit	071323 MNACH	7/13/2023	(\$133.32)	(\$133.32)	-	-
Deposit	071423 Deposit	7/14/2023	(\$12,786.05)	(\$12,786.05)	-	-
Deposit	071723 Deposit	7/17/2023	(\$18,111.51)	(\$18,111.51)	-	-
Deposit	071823 Deposit	7/18/2023	(\$61,559.38)	(\$61,559.38)	-	-
Deposit	071923 Deposit	7/19/2023	(\$2,027.38)	(\$2,027.38)	-	-
Deposit	072023 MNACH	7/20/2023	(\$214,213.00)	(\$214,213.00)	-	-
Deposit	072123 MNACH	7/21/2023	(\$650.00)	(\$650.00)	-	-
Deposit	072123 OptumReimb	7/21/2023	(\$7,000.00)	(\$7,000.00)	-	-
Deposit	WCTA Franchise	7/24/2023	(\$500.00)	(\$500.00)	-	-
Deposit	072823 Deposit	7/28/2023	(\$1,792.13)	(\$1,792.13)	-	-
Deposit	070323 MNACH	7/31/2023	(\$500.00)	(\$500.00)	-	-
Deposit	073123EOM LS etc	7/31/2023	(\$157,955.67)	(\$157,955.67)	-	-
Deposit	20230811UB3	8/11/2023	(\$376.06)	(\$376.06)	-	-
Deposit	20230811UB5	8/11/2023	(\$187.81)	(\$187.81)	-	-
Deposit	20230811UB25	8/11/2023	(\$40.49)	(\$40.49)	-	-
Deposit	20230811UB26	8/11/2023	(\$65.20)	(\$65.20)	-	-
Deposit	20230811UB21	8/11/2023	(\$40.87)	(\$40.87)	-	-
Deposit	20230811UB9	8/11/2023	(\$10,604.42)	(\$10,604.42)	-	-
Deposit	20230811UB27	8/11/2023	(\$29.00)	(\$29.00)	-	-
Deposit	POS COM02017 Jul-03	8/11/2023	(\$5,831.25)	(\$5,831.25)	-	-
Deposit	20230811UB1	8/11/2023	(\$5,318.82)	(\$5,318.82)	-	-
Deposit	20230811UB12	8/11/2023	(\$810.32)	(\$810.32)	-	-
Deposit	20230811UB16	8/11/2023	(\$140.91)	(\$140.91)	-	-
Deposit	POS COM02017 Jul-18	8/11/2023	(\$799.53)	(\$799.53)	-	-
Deposit	POS COM02017 Jul-24	8/11/2023	(\$2,330.32)	(\$2,330.32)	-	-
Deposit	POS COM02017 Jul-26	8/11/2023	(\$716.04)	(\$716.04)	-	-
Deposit	POS COM02017 Jul-25	8/11/2023	(\$1,786.64)	(\$1,786.64)	-	-
Deposit	POS COM02017 Jul-27	8/11/2023	(\$739.32)	(\$739.32)	-	-
Deposit	POS COM02017 Jul-28	8/11/2023	(\$1,274.30)	(\$1,274.30)	-	-
Deposit	POS COM02017 Jul-31	8/11/2023	(\$4,506.52)	(\$4,506.52)	-	-
Deposit	20230817UB2	8/17/2023	(\$202.02)	(\$202.02)	-	-
Deposit	20230817UB4	8/17/2023	(\$67.58)	(\$67.58)	-	-
Deposit	20230817UB1	8/17/2023	(\$115.87)	(\$115.87)	-	-
Deposit	20230817UB3	8/17/2023	(\$158.18)	(\$158.18)	-	-
Deposit	POS COM02017 Jul-14	8/17/2023	(\$805.71)	(\$805.71)	-	-
Deposit	POS COM02017 Jul-17	8/17/2023	(\$2,207.35)	(\$2,207.35)	-	-
Deposit	20230822UB0	8/22/2023	(\$514.69)	(\$514.69)	-	-
Deposit	20230822UB1	8/22/2023	(\$42.50)	(\$42.50)	-	-
Deposit	20230822UB2	8/22/2023	(\$117.70)	(\$117.70)	-	-
Deposit	20230822UB3	8/22/2023	(\$983.93)	(\$983.93)	-	-
Deposit	POS COM02017 Jul-11	8/23/2023	(\$9,903.02)	(\$9,903.02)	-	-
Deposit	POS COM02015 Jul-12	8/24/2023	(\$1,456.48)	(\$1,456.48)	-	-
504758E	Bi-Weekly ACH	7/5/2023	\$20,864.32	\$20,864.32	-	-

CITY OF MENAHGA

*Check Reconciliation©

GENERAL CHECKING

10100 GEN CHECK

Check Nbr	Vendor Name	Check Date	Amount	Cleared This Month	Amount Not Cleared	Partially Cleared Last Month
001946E	NORTHBOUND SPIRITS	7/6/2023	\$3,000.00	\$3,000.00	-	-
001947E	OPTUM BANK	7/12/2023	\$7,000.00	\$7,000.00	-	-
504777E	Bi-Weekly ACH	7/19/2023	\$22,169.10	\$22,169.10	-	-
504781E	Bi-Weekly ACH	7/21/2023	\$1,005.69	\$1,005.69	-	-
001945E	ELIOT	7/27/2023	\$130.95	\$130.95	-	-
001929E	AUTHORIZE.NET	8/10/2023	\$26.15	\$26.15	-	-
001930E	COLONIAL LIFE PROCESSING CTR	8/10/2023	\$46.24	\$46.24	-	-
001931E	DELTA DENTAL	8/10/2023	\$911.62	\$911.62	-	-
001932E	DELUXE	8/10/2023	\$94.03	\$94.03	-	-
001933E	ELEMENT/VANTIV	8/10/2023	\$2,495.01	\$2,495.01	-	-
001934E	ELIOT	8/10/2023	\$136.09	\$136.09	-	-
001935E	HEALTH PARTNERS	8/10/2023	\$10,066.96	\$10,066.96	-	-
001936E	INTERNAL REVENUE SERVICE	8/10/2023	\$11,682.21	\$11,682.21	-	-
001937E	MN DEPARTMENT OF REVENUE	8/10/2023	\$13,304.27	\$13,304.27	-	-
001938E	OPTUM BANK	8/10/2023	\$8,750.00	\$8,750.00	-	-
001939E	PERA	8/10/2023	\$10,002.61	\$10,002.61	-	-
001940E	RESNEXUS	8/10/2023	\$69.00	\$69.00	-	-
001941E	VERIZON CONNECT FLEET USA LLC	8/10/2023	\$539.01	\$539.01	-	-
001942E	WEST CENTRAL TELEPHONE	8/10/2023	\$1,921.23	\$1,921.23	-	-
001943E	WEX BANK	8/10/2023	\$1,096.77	\$1,096.77	-	-
001944E	AUTHORIZE.NET	8/23/2023	\$0.30	\$0.30	-	-
019411	LESTINA, ANDREA W.	7/19/2023	\$95.85	\$95.85	-	-
019412	LOPEZ, ERIKA L.	7/19/2023	\$95.85	\$95.85	-	-
060763	RIFE, MARK	3/8/2021	\$537.45	-	\$537.45	-
061590	FARNAMS GENUINE PARTS, INC	1/27/2022	\$474.82	-	\$474.82	-
061859	GOPHER STATE ONE-CALL	5/9/2022	\$17.55	-	\$17.55	-
062568	ZANDER, ELLIOT & FRANCES	12/30/2022	\$68.55	-	\$68.55	-
062981	NETLAND, MICHAEL	5/8/2023	\$87.77	-	\$87.77	-
063091	MENAHGA CONCRETE PRODUCTS	6/12/2023	\$2,178.41	\$2,178.41	-	-
063095	MN RURAL WATER ASSOCIATION	6/12/2023	\$542.45	\$542.45	-	-
063117	BANYON DATA SYSTEMS, INC	6/26/2023	\$2,495.00	\$2,495.00	-	-
063118	BERNICKS	6/26/2023	\$1,243.40	\$1,243.40	-	-
063119	BEVERAGE WHOLESAL	6/26/2023	\$3,818.70	\$3,818.70	-	-
063120	BLUE CLOUD DISTRIBUTION OF MN IN	6/26/2023	\$851.00	\$851.00	-	-
063122	Brian Waterman	6/26/2023	\$2,550.00	\$2,550.00	-	-
063124	CINTAS	6/26/2023	\$190.13	\$190.13	-	-
063125	CINTAS	6/26/2023	\$155.43	\$155.43	-	-
063127	CREATIVE WORLD, LLC	6/26/2023	\$2,400.00	\$2,400.00	-	-
063128	CWIKLA ACE HARDWARE	6/26/2023	\$13.99	\$13.99	-	-
063129	DACOTAH PAPER CO.	6/26/2023	\$121.70	\$121.70	-	-
063130	DAHLHEIMER BEVERAGE BRAINERD	6/26/2023	\$11,515.29	\$11,515.29	-	-
063131	DEPARTMENT OF HUMAN SERVICES	6/26/2023	\$9,381.31	\$9,381.31	-	-
063132	DIAMOND MAPS	6/26/2023	\$288.00	\$288.00	-	-
063133	D-S BEVERAGES INC	6/26/2023	\$13,677.93	\$13,677.93	-	-
063134	F.I.R.E.	6/26/2023	\$650.00	\$650.00	-	-
063135	FLAHERTY & HOOD, P.A.	6/26/2023	\$4,561.25	\$4,561.25	-	-
063136	G & T SANITATION, INC.	6/26/2023	\$476.33	\$476.33	-	-
063137	GATEWAY LIONS	6/26/2023	\$1,200.00	\$1,200.00	-	-
063138	GIOVANNI S	6/26/2023	\$353.10	\$353.10	-	-

CITY OF MENA HGA

*Check Reconciliation©

GENERAL CHECKING

10100 GEN CHECK

Check Nbr	Vendor Name	Check Date	Amount	Cleared This Month	Amount Not Cleared	Partially Cleared Last Month
063139	GRANITE CITY JOBBING CO.	6/26/2023	\$1,000.27	\$1,000.27	-	-
063140	GREAT PLAINS FIRE	6/26/2023	\$3,212.47	\$3,212.47	-	-
063141	GREENER TOMORROWS	6/26/2023	\$687.91	\$687.91	-	-
063142	HAWKINS, INC.	6/26/2023	\$255.00	\$255.00	-	-
063143	HEGGIES PIZZA	6/26/2023	\$486.60	\$486.60	-	-
063144	Innovative Office Solutions, LLC	6/26/2023	\$99.14	\$99.14	-	-
063145	JOHNSON BROTHERS LIQUOR	6/26/2023	\$5,046.48	\$5,046.48	-	-
063146	K & K TRUCK & AUTO REPAIR	6/26/2023	\$2,427.56	\$2,427.56	-	-
063147	KIESLER POLICE SUPPLY	6/26/2023	\$1,150.74	\$1,150.74	-	-
063148	LAW ENFORCEMENT LABOR SERVICE	6/26/2023	\$169.24	\$169.24	-	-
063150	MINNESOTA PUMP WORKS	6/26/2023	\$1,273.00	\$1,273.00	-	-
063151	NETLAND, MICHAEL	6/26/2023	\$55.02	-	\$55.02	-
063152	PARK RAPIDS COMMUNITY BAND	6/26/2023	\$400.00	\$400.00	-	-
063153	PEPSI COLA	6/26/2023	\$621.84	\$621.84	-	-
063154	PHILLIPS WINE & SPIRITS	6/26/2023	\$1,902.93	\$1,902.93	-	-
063155	POSTMASTER	6/26/2023	\$146.00	\$146.00	-	-
063156	R&R RENTAL	6/26/2023	\$33.00	\$33.00	-	-
063157	RAMSTAD, SKOYLES & WINTERS, PA	6/26/2023	\$87.30	\$87.30	-	-
063158	S.C.D. TAP BEER LINE CLEANING	6/26/2023	\$42.00	\$42.00	-	-
063159	SOURCEWELL	6/26/2023	\$577.50	\$577.50	-	-
063160	SOUTHERN GLAZERS OF MN	6/26/2023	\$2,272.67	\$2,272.67	-	-
063161	SPIRIT LAKE LUMBER	6/26/2023	\$127.11	\$127.11	-	-
063162	STATE CHEMICAL SOLUTIONS	6/26/2023	\$254.75	\$254.75	-	-
063163	TASC	6/26/2023	\$16.04	\$16.04	-	-
063164	TEAM LABORATORY CHEMICAL	6/26/2023	\$1,080.00	\$1,080.00	-	-
063165	TEAMSTERS LOCAL UNION 346	6/26/2023	\$125.00	\$125.00	-	-
063166	TEDS HARDWARE MENA HGA	6/26/2023	\$119.04	\$119.04	-	-
063167	THE MCDOWELL AGENCY	6/26/2023	\$35.00	\$35.00	-	-
063168	THOMSEN, BETTY, J.	6/26/2023	\$2,103.75	\$2,103.75	-	-
063169	UNUM LIFE INS CO OF AMERICA	6/26/2023	\$63.90	\$63.90	-	-
063170	VEIT & COMPANY, INC.	6/26/2023	\$4,487.50	\$4,487.50	-	-
063171	VESSCO, INC	6/26/2023	\$70.69	\$70.69	-	-
063172	VIKING COCA-COLA BOTTLING	6/26/2023	\$194.30	\$194.30	-	-
063173	WADENA COUNTY AUDITOR/TREAS	6/26/2023	\$13.18	\$13.18	-	-
063174	WADENA COUNTY DAC	6/26/2023	\$140.60	\$140.60	-	-
063175	WARNICKS JANITORIAL SERVICE	6/26/2023	\$170.00	\$170.00	-	-
063176	WHITE, JOSEPH	6/26/2023	\$31.90	\$31.90	-	-
063177	MINNESOTA POWER	6/28/2023	\$7,074.95	\$7,074.95	-	-
063178	BLONDE & THE BOHUNK	6/28/2023	\$2,500.00	\$2,500.00	-	-
063179	ALAJOKI SAND & GRAVEL	7/7/2023	\$211.20	\$211.20	-	-
063180	ARCTIC GLACIER	7/7/2023	\$240.55	\$240.55	-	-
063181	ASTERA	7/7/2023	\$200.00	\$200.00	-	-
063182	BERNICKS	7/7/2023	\$579.50	\$579.50	-	-
063183	BEVERAGE WHOLESALE	7/7/2023	\$3,147.05	\$3,147.05	-	-
063184	BOND TRUST SERVICES	7/7/2023	\$74,568.13	\$74,568.13	-	-
063185	BREAKTHRU BEVERAGE	7/7/2023	\$3,894.17	\$3,894.17	-	-
063186	CINTAS	7/7/2023	\$101.66	\$101.66	-	-
063187	DACOTAH PAPER CO.	7/7/2023	\$584.29	\$584.29	-	-
063188	DAHLHEIMER BEVERAGE BRAINERD	7/7/2023	\$8,575.50	\$8,575.50	-	-

CITY OF MENA HGA

*Check Reconciliation©

GENERAL CHECKING

10100 GEN CHECK

Check Nbr	Vendor Name	Check Date	Amount	Cleared This Month	Amount Not Cleared	Partially Cleared Last Month
063189	D-S BEVERAGES INC	7/7/2023	\$6,511.59	\$6,511.59	-	-
063190	EHLERS	7/7/2023	\$265.00	\$265.00	-	-
063191	ELECTRIC PUMP INC	7/7/2023	\$10,158.51	\$10,158.51	-	-
063192	GATEWAY LIONS	7/7/2023	\$50.00	\$50.00	-	-
063193	GIOVANNI S	7/7/2023	\$438.75	\$438.75	-	-
063194	GOVOFFICE	7/7/2023	\$699.60	\$699.60	-	-
063195	GRANITE CITY JOBBING CO.	7/7/2023	\$822.33	\$822.33	-	-
063196	HAWKINS, INC.	7/7/2023	\$2,824.38	\$2,824.38	-	-
063197	HEGGIES PIZZA	7/7/2023	\$309.35	\$309.35	-	-
063198	Innovative Office Solutions, LLC	7/7/2023	\$201.13	\$201.13	-	-
063199	JANSSEN, ZAYNE	7/7/2023	\$30.13	\$30.13	-	-
063200	JOHNSON BROTHERS LIQUOR	7/7/2023	\$4,694.78	\$4,694.78	-	-
063201	K & K TRUCK & AUTO REPAIR	7/7/2023	\$127.50	\$127.50	-	-
063202	L&M SUPPLY, INC.	7/7/2023	\$59.98	\$59.98	-	-
063203	LAKE COUNTRY FOODS	7/7/2023	\$83.21	\$83.21	-	-
063204	LEAGUE OF MN CITIES INSUR TRST	7/7/2023	\$75,745.00	\$75,745.00	-	-
063205	MENA HGA CONCRETE	7/7/2023	\$1,506.37	-	\$1,506.37	-
063206	MINNESOTA BACKFLOW	7/7/2023	\$1,457.07	\$1,457.07	-	-
063207	MINNESOTA CHIEFS OF POLICE	7/7/2023	\$244.00	\$244.00	-	-
063208	NAPA CENTRAL - MN	7/7/2023	\$235.13	\$235.13	-	-
063209	PHILLIPS WINE & SPIRITS	7/7/2023	\$4,523.49	\$4,523.49	-	-
063210	PIETILA, RACHAEL	7/7/2023	\$30.13	\$30.13	-	-
063211	SHELL SPORT & BAIT	7/7/2023	\$426.74	\$426.74	-	-
063212	SOUTHERN GLAZERS OF MN	7/7/2023	\$2,187.78	\$2,187.78	-	-
063213	SPIRIT LAKE LUMBER	7/7/2023	\$137.86	\$137.86	-	-
063214	STREICHERS	7/7/2023	\$104.98	\$104.98	-	-
063215	SWIPECLOCK, LLC	7/7/2023	\$105.00	\$105.00	-	-
063216	TEAM LABORATORY CHEMICAL	7/7/2023	\$167.25	\$167.25	-	-
063217	THOMSEN, BETTY, J.	7/7/2023	\$1,691.25	\$1,691.25	-	-
063218	VERIZON CONNECT FLEET USA LLC	7/7/2023	\$151.60	\$151.60	-	-
063219	VIKING COCA-COLA BOTTLING	7/7/2023	\$425.75	\$425.75	-	-
063220	WADENA COUNTY RECORDER	7/7/2023	\$46.00	\$46.00	-	-
063221	WHITE, JOSEPH	7/7/2023	\$23.61	\$23.61	-	-
063222	GALACTIC COWBOY ORCHESTRA	7/14/2023	\$1,500.00	\$1,500.00	-	-
063223	MONROE CROSSING, INC	7/14/2023	\$3,000.00	\$3,000.00	-	-
063224	WILKINSON JAMES	7/14/2023	\$800.00	\$800.00	-	-
063234	BOND TRUST SERVICES	7/14/2023	\$475.00	\$475.00	-	-
063235	CINTAS	7/14/2023	\$105.87	-	\$105.87	-
063236	CULLIGAN OF WADENA	7/14/2023	\$51.75	\$51.75	-	-
063237	FERGUSON WATERWORKS #2516	7/14/2023	\$3,027.07	\$3,027.07	-	-
063238	G & T SANITATION, INC.	7/14/2023	\$730.40	\$730.40	-	-
063239	GALL S LLC	7/14/2023	\$103.75	\$103.75	-	-
063240	K & K TRUCK & AUTO REPAIR	7/14/2023	\$53.50	\$53.50	-	-
063241	LAKES AREA COOP -2 MENA HGA	7/14/2023	\$44.49	\$44.49	-	-
063242	MACQUEEN EQUIPMENT GROUP	7/14/2023	\$1,737.35	\$1,737.35	-	-
063243	MARCO	7/14/2023	\$366.72	\$366.72	-	-
063244	MINNESOTA ENERGY RESOURCES	7/14/2023	\$123.95	\$123.95	-	-
063245	PLEASANT PINE ACRES	7/14/2023	\$8,733.67	\$8,733.67	-	-
063246	REVIEW MESSENGER	7/14/2023	\$209.00	\$209.00	-	-

CITY OF MENA HGA

*Check Reconciliation©

GENERAL CHECKING

10100 GEN CHECK

Check Nbr	Vendor Name	Check Date	Amount	Cleared This Month	Amount Not Cleared	Partially Cleared Last Month
063247	SOUTHERN GLAZERS OF MN	7/14/2023	\$16.00	\$16.00	-	-
063248	TED S HARDWARE SEBEKA	7/14/2023	\$15.98	\$15.98	-	-
063249	TEDS HARDWARE MENA HGA	7/14/2023	\$116.42	\$116.42	-	-
063250	VERIZON CONNECT FLEET USA LLC	7/14/2023	\$151.60	\$151.60	-	-
063251	POSTMASTER	7/18/2023	\$248.64	\$248.64	-	-
063252	TODD-WADENA ELECTRIC COOP	7/18/2023	\$75.41	\$75.41	-	-
063258	ARCTIC GLACIER	7/31/2023	\$1,067.74	-	\$1,067.74	-
063259	ASPHALT PRESERVATION COMPANY	7/31/2023	\$46,885.75	-	\$46,885.75	-
063260	BERNICKS	7/31/2023	\$650.90	-	\$650.90	-
063261	BEVERAGE WHOLESale	7/31/2023	\$5,963.25	-	\$5,963.25	-
063262	BLUE CLOUD DISTRIBUTION OF MN IN	7/31/2023	\$560.00	-	\$560.00	-
063263	BREAKTHRU BEVERAGE	7/31/2023	\$6,104.04	-	\$6,104.04	-
063264	CINTAS	7/31/2023	\$479.73	-	\$479.73	-
063265	CITY AUTO GLASS INC.	7/31/2023	\$431.78	-	\$431.78	-
063266	CITY OF MENA HGA	7/31/2023	\$424.91	-	\$424.91	-
063267	CLASSIC KELLY KARAOKE	7/31/2023	\$280.00	-	\$280.00	-
063268	DACOTAH PAPER CO.	7/31/2023	\$194.70	-	\$194.70	-
063269	DAHLHEIMER BEVERAGE BRAINERD	7/31/2023	\$17,570.65	-	\$17,570.65	-
063270	DEPARTMENT OF HUMAN SERVICES	7/31/2023	\$9,381.31	-	\$9,381.31	-
063271	D-S BEVERAGES INC	7/31/2023	\$17,093.76	-	\$17,093.76	-
063272	ECOLAB	7/31/2023	\$66.99	-	\$66.99	-
063273	ELSNER WELL DRILLING, INC	7/31/2023	\$3,539.74	-	\$3,539.74	-
063274	FLAHERTY & HOOD, P.A.	7/31/2023	\$4,297.50	-	\$4,297.50	-
063275	G & T SANITATION, INC.	7/31/2023	\$675.00	-	\$675.00	-
063276	GIOVANNI S	7/31/2023	\$484.25	-	\$484.25	-
063277	GRANITE CITY JOBBING CO.	7/31/2023	\$779.47	-	\$779.47	-
063278	GREIMANS	7/31/2023	\$10.00	-	\$10.00	-
063279	HAWKINS, INC.	7/31/2023	\$616.10	-	\$616.10	-
063280	HEGGIES PIZZA	7/31/2023	\$158.30	-	\$158.30	-
063281	HEIMAN FIRE EQUIPMENT	7/31/2023	\$649.00	-	\$649.00	-
063282	Innovative Office Solutions, LLC	7/31/2023	\$290.88	-	\$290.88	-
063283	J & S HANDYMAN & LAKESHORE INC	7/31/2023	\$300.00	-	\$300.00	-
063284	JOHNSON BROTHERS LIQUOR	7/31/2023	\$6,456.94	-	\$6,456.94	-
063285	K & K TRUCK & AUTO REPAIR	7/31/2023	\$53.50	-	\$53.50	-
063286	KUMPULA, RALPH	7/31/2023	\$209.70	-	\$209.70	-
063287	L&B CONSTRUCTION, INC.	7/31/2023	\$5,870.00	-	\$5,870.00	-
063288	LAKES AREA COOP -1 PERHAM	7/31/2023	\$3,440.00	-	\$3,440.00	-
063289	LAW ENFORCEMENT LABOR SERVICE	7/31/2023	\$135.00	-	\$135.00	-
063290	MN PUBLIC FACILITIES AUTHORITY	7/31/2023	\$31,192.46	-	\$31,192.46	-
063291	NATHAN SCHAPER	7/31/2023	\$500.00	-	\$500.00	-
063292	PARK RAPIDS FORD	7/31/2023	\$107.45	-	\$107.45	-
063293	PEDERSON OIL SERVICES, INC.	7/31/2023	\$1,855.36	-	\$1,855.36	-
063294	PEPSI COLA	7/31/2023	\$173.71	-	\$173.71	-
063295	PHILLIPS WINE & SPIRITS	7/31/2023	\$3,565.11	-	\$3,565.11	-
063296	RMB ENVIRONMENTAL LABS	7/31/2023	\$71.88	-	\$71.88	-
063297	S.C.D. TAP BEER LINE CLEANING	7/31/2023	\$42.00	-	\$42.00	-
063298	SHELL SPORT & BAIT	7/31/2023	\$1,822.33	-	\$1,822.33	-
063299	SOURCEWELL	7/31/2023	\$178.75	-	\$178.75	-
063300	SOUTHERN GLAZERS OF MN	7/31/2023	\$3,770.34	-	\$3,770.34	-

CITY OF MENAUGA

*Check Reconciliation©

GENERAL CHECKING
10100 GEN CHECK

Check Nbr	Vendor Name	Check Date	Amount	Cleared This Month	Amount Not Cleared	Partially Cleared Last Month
063301	SWIPECLOCK, LLC	7/31/2023	\$105.00	-	\$105.00	-
063302	TASC	7/31/2023	\$16.04	-	\$16.04	-
063303	TEAM LABORATORY CHEMICAL	7/31/2023	\$145.00	-	\$145.00	-
063304	TEAMSTERS LOCAL UNION 346	7/31/2023	\$125.00	-	\$125.00	-
063305	THE RUSTIC INN	7/31/2023	\$267.00	-	\$267.00	-
063306	ULTEIG ENG	7/31/2023	\$1,149.30	-	\$1,149.30	-
063307	UNUM LIFE INS CO OF AMERICA	7/31/2023	\$75.90	-	\$75.90	-
063308	VIKING COCA-COLA BOTTLING	7/31/2023	\$219.15	-	\$219.15	-
063309	VKM CREATIONS LLC	7/31/2023	\$936.00	-	\$936.00	-
063310	WADENA COUNTY ATTORNEY	7/31/2023	\$700.00	-	\$700.00	-
063311	WADENA COUNTY DAC	7/31/2023	\$118.40	-	\$118.40	-
063312	WADENA COUNTY RECORDER	7/31/2023	\$15.00	-	\$15.00	-
063313	WADENA COUNTY TREASURER	7/31/2023	\$1,680.00	-	\$1,680.00	-
063314	WARNICKS JANITORIAL SERVICE	7/31/2023	\$170.00	-	\$170.00	-
063315	MINNESOTA POWER	7/31/2023	\$6,727.58	-	\$6,727.58	-
063366 *	MAGUIRE IRON, INC.	8/14/2023	\$0.00	-	-	-
063367 *	TODD-WADENA ELECTRIC COOP	8/14/2023	\$0.00	-	-	-
063368 *	ULTEIG ENG	8/14/2023	\$0.00	-	-	-
Receipts/Deposits			(\$535,723.38)	(\$535,723.38)	\$0.00	\$0.00
Payments/Withdrawal			\$193,703.05	\$443,327.67	\$193,703.05	\$0.00

Total Deposits (\$535,723.38)
Total Checks Written \$637,030.72
(Outstanding + Cleared)

*Next month items not included in Total Deposits & Checks Written

CITY OF MENAHGA

***Profit Loss Summary By Fund YTD©**

As of July 2023

	July 2023	YTD Totals
101 GENERAL FUND		
Revenues	\$239,158.82	\$723,465.21
Expenditures	\$129,231.03	\$821,466.24
Gain(Loss) GENERAL FUND	\$109,927.79	(\$98,001.03)
220 Fire Department		
Revenues	\$0.00	\$0.00
Gain(Loss) Fire Department	None	None
226 ECONOMIC DEV REVOLVING LN FD		
Revenues	\$149.09	\$2,224.83
Expenditures	\$0.00	\$0.00
Gain(Loss) ECONOMIC DEV REVOLVING LN FD	\$149.09	\$2,224.83
228 TIF DISTRICT PEDRO		
Revenues	\$0.00	\$35.22
Expenditures	\$0.00	\$0.00
Gain(Loss) TIF DISTRICT PEDRO	None	\$35.22
233 TIF DISTRICT 1-6 PLEASANT PINE		
Revenues	\$0.00	\$9,704.08
Expenditures	\$8,998.67	\$16,104.57
Gain(Loss) TIF DISTRICT 1-6 PLEASANT PINE	(\$8,998.67)	(\$6,400.49)
303 1990 CITY HALL DEBT FUND		
Revenues	\$0.00	\$36.13
Expenditures	\$509.12	\$509.12
Gain(Loss) 1990 CITY HALL DEBT FUND	(\$509.12)	(\$472.99)
304 2012A FIRE TRUCK		
Revenues	\$0.00	\$0.00
Expenditures	\$0.00	\$0.00
Gain(Loss) 2012A FIRE TRUCK	None	None
307 WATER SEWER DEBT		
Revenues	\$10,332.64	\$26,664.36
Expenditures	\$146,162.19	\$146,162.19
Gain(Loss) WATER SEWER DEBT	(\$135,829.55)	(\$119,497.83)
310 2012a NURSING HOME DEBT FUND		
Revenues	\$61,559.38	\$335,235.17
Expenditures	\$61,559.38	\$335,668.76
Gain(Loss) 2012a NURSING HOME DEBT FUND	None	(\$433.59)
311 2003 IMPROVEMENT DEBT FUND		
Revenues	\$0.00	\$84.32
Expenditures	\$1,085.05	\$1,085.05

CITY OF MENAHGA

***Profit Loss Summary By Fund YTD©**

As of July 2023

	July 2023	YTD Totals
Gain(Loss) 2003 IMPROVEMENT DEBT FUND	(\$1,085.05)	(\$1,000.73)
312 2004 IMPROVEMENT DEBT FUND		
Revenues	\$0.00	\$247.27
Expenditures	\$4,959.94	\$4,959.94
Gain(Loss) 2004 IMPROVEMENT DEBT FUND	(\$4,959.94)	(\$4,712.67)
313 2006 UTILITY/STREET IMPROV		
Revenues	\$146,162.19	\$146,162.19
Expenditures	\$0.00	\$0.00
Gain(Loss) 2006 UTILITY/STREET IMPROV	\$146,162.19	\$146,162.19
314 SPECIAL PROJECT DEBT FUND		
Revenues	\$0.00	\$0.00
Expenditures	\$0.00	\$0.00
Gain(Loss) SPECIAL PROJECT DEBT FUND	None	None
315 2009 GO IMPROVEMENT		
Revenues	\$0.00	\$0.00
Expenditures	\$0.00	\$0.00
Gain(Loss) 2009 GO IMPROVEMENT	None	None
316 2013 STREET & UTILITY IMPROVEM		
Revenues	\$0.00	\$43,171.86
Expenditures	\$2,500.00	\$25,975.00
Gain(Loss) 2013 STREET & UTILITY IMPROVEM	(\$2,500.00)	\$17,196.86
317 2015B Imp. Refunding GO Bond		
Revenues	\$0.00	\$27,857.40
Expenditures	\$5,676.25	\$67,377.50
Gain(Loss) 2015B Imp. Refunding GO Bond	(\$5,676.25)	(\$39,520.10)
318 2020A GO Improvement Refunding		
Revenues	\$0.00	\$32,878.10
Expenditures	\$5,307.50	\$160,890.00
Gain(Loss) 2020A GO Improvement Refunding	(\$5,307.50)	(\$128,011.90)
404 2009 CSAH 21		
Revenues	\$0.00	\$0.00
Expenditures	\$0.00	\$0.00
Gain(Loss) 2009 CSAH 21	None	None
406 CAPITAL PROJECTS-EQUIPMENT		
Revenues	\$817.44	\$17,502.59
Expenditures	\$46,885.75	\$46,885.75
Gain(Loss) CAPITAL PROJECTS-EQUIPMENT	(\$46,068.31)	(\$29,383.16)
414 2017 N.H. CONST-CAPITAL PROJ		

***Profit Loss Summary By Fund YTD©**

As of July 2023

July 2023

YTD Totals

	July 2023	YTD Totals
Revenues	\$0.00	\$0.00
Expenditures	\$0.00	\$0.00
Gain(Loss) 2017 N.H. CONST-CAPITAL PROJ	None	None
415 2020a Bond		
Revenues	\$0.00	\$0.00
Expenditures	\$0.00	\$0.00
Gain(Loss) 2020a Bond	None	None
416 Region 5 Energy Initiative		
Revenues	\$0.00	\$11,472.15
Expenditures	\$209.00	\$5,020.94
Gain(Loss) Region 5 Energy Initiative	(\$209.00)	\$6,451.21
417 Water Tower Construction		
Revenues	\$0.00	\$64,103.43
Expenditures	\$1,149.30	\$67,234.00
Gain(Loss) Water Tower Construction	(\$1,149.30)	(\$3,130.57)
418 TH87 Watermain Replacement		
Revenues	\$0.00	\$0.00
Expenditures	\$0.00	\$3,980.00
Gain(Loss) TH87 Watermain Replacement	None	(\$3,980.00)
601 WATER FUND		
Revenues	\$27,760.28	\$183,536.39
Expenditures	\$67,355.47	\$142,990.36
Gain(Loss) WATER FUND	(\$39,595.19)	\$40,546.03
602 SEWER FUND		
Revenues	\$17,016.63	\$118,319.62
Expenditures	\$31,482.78	\$118,243.05
Gain(Loss) SEWER FUND	(\$14,466.15)	\$76.57
607 CEMETERY FUND		
Revenues	\$1,021.96	\$1,506.28
Expenditures	\$186.37	\$186.37
Gain(Loss) CEMETERY FUND	\$835.59	\$1,319.91
609 MUNICIPAL LIQUOR FUND		
Revenues	\$147,885.98	\$705,427.33
Expenditures	\$141,026.48	\$638,981.20
Gain(Loss) MUNICIPAL LIQUOR FUND	\$6,859.50	\$66,446.13
755 GET HOOKED ON FISHING		
Revenues	\$0.00	\$4,193.33
Expenditures	\$1,822.33	\$2,423.72

CITY OF MENAHGA

***Profit Loss Summary By Fund YTD©**

As of July 2023

	July 2023	YTD Totals
Gain(Loss) GET HOOKED ON FISHING	(\$1,822.33)	\$1,769.61
760 SOUNDS OF SPIRIT LAKE		
Revenues	\$3,688.14	\$11,558.93
Expenditures	\$6,276.70	\$10,177.26
Gain(Loss) SOUNDS OF SPIRIT LAKE	(\$2,588.56)	\$1,381.67
765 BRE PROJECTS		
Revenues	\$0.00	\$7.52
Expenditures	\$0.00	\$0.00
Gain(Loss) BRE PROJECTS	None	\$7.52
770 Frisbee Golf		
Expenditures	\$0.00	\$0.00
Gain(Loss) Frisbee Golf	None	None
800 American Rescue Plan		
Revenues	\$0.00	\$0.00
Expenditures	\$0.00	\$2,255.86
Gain(Loss) American Rescue Plan	None	(\$2,255.86)
999 Covid 19-		
Expenditures	\$0.00	\$0.00
Gain(Loss) Covid 19-	None	None
Grand Total CITY OF MENAHGA Gain(Loss)	(\$6,830.76)	(\$153,183.17)

Investment Portfolio Pledged Securities
 COMMUNITY FIRST BANK
 MENA HGA, MN

InTrader (pledged)
 Last : 06/30/2023
 As-of: 07/31/2023
 1587 100792

Sec ID	Ticket	Security Description Line 1	Security Description Line 2	Safekeeping Agent	Rate	Maturity	Grp	Original Face S & P	Par/Curr Face Moody	Priced Pledged	Book Value	Market Value
PLEGGED TO: j49 CITY OF MENA HGA												
91282CBH3		US TREASURY NOTE		UNITED BANKERS BANK				200,000.00 AA+		07/27/2023	196,437.66	
UBB	154022551			.375	01/31/2026		010	200,000.00 Aaa		02/25/2022	180,109.38	
91282CBW0		US TREASURY NOTE		UNITED BANKERS BANK				50,000.00 AA+		07/27/2023	50,013.52	
UBB	154021579			.75	04/30/2026		010	50,000.00 Aaa		11/18/2021	45,158.20	
3133EMINV0		FED FARM CREDIT BANK		UNITED BANKERS BANK				100,000.00 AA+		07/27/2023	100,000.00	
UBB	154020839	NON CALLABLE		.6	01/27/2027		100	100,000.00 Aaa		09/08/2021	87,478.99	
586328JF4		MENAHGA MN GO		UNITED BANKERS BANK				100,000.00 NR		07/31/2023	100,199.23	
UBB	154020286	NON CALLABLE		1	02/01/2024		200	100,000.00 NR		11/16/2020	98,820.06	
586328JF4		MENAHGA MN GO		UNITED BANKERS BANK				50,000.00 NR		07/31/2023	50,099.61	
UBB	154020286	NON CALLABLE		1	02/01/2024		200	50,000.00 NR		11/16/2020	49,410.03	
586328JG2		MENAHGA MN GO		UNITED BANKERS BANK				100,000.00 NR		07/31/2023	100,446.57	
UBB	154020287	NON CALLABLE		1	02/01/2025		200	100,000.00 NR		07/31/2023	96,660.80	
586328JG2		MENAHGA MN GO		UNITED BANKERS BANK				50,000.00 NR		07/31/2023	50,223.29	
UBB	154020287	NON CALLABLE		1	02/01/2025		200	50,000.00 NR		01/11/2021	48,330.40	
586328JH0		MENAHGA MN GO		UNITED BANKERS BANK				155,000.00 NR		07/31/2023	155,764.94	
UBB	154020288	NON CALLABLE		1	02/01/2026		200	155,000.00 NR		11/23/2020	147,084.21	
586328JJ6		MENAHGA MN GO		UNITED BANKERS BANK				155,000.00 NR		07/31/2023	155,265.12	
UBB	154020289	NON CALLABLE		1	02/01/2027		200	155,000.00 NR		11/24/2020	144,625.40	
586328JK3		MENAHGA MN GO		UNITED BANKERS BANK				65,000.00 NR		07/31/2023	65,000.00	
UBB	154020290	NON CALLABLE		1.1	02/01/2028		200	65,000.00 NR		11/24/2020	59,915.21	
586328JK3		MENAHGA MN GO		UNITED BANKERS BANK				90,000.00 NR		07/31/2023	90,000.00	
UBB	154020290	NON CALLABLE		1.1	02/01/2028		200	90,000.00 NR		11/23/2020	82,959.53	
586328JL1		MENAHGA MN GO		UNITED BANKERS BANK				100,000.00 NR		07/31/2023	100,000.00	
UBB	154020291	NON CALLABLE		1.2	02/01/2029		200	100,000.00 NR		01/11/2021	91,270.88	
586328JL1		MENAHGA MN GO		UNITED BANKERS BANK				25,000.00 NR		07/31/2023	25,000.00	
UBB	154020291	NON CALLABLE		1.2	02/01/2029		200	25,000.00 NR		11/24/2020	22,817.72	
05600XAV2		BMO HARRIS BANK CD		UNITED BANKERS BANK				30,000.00 NR		07/31/2023	30,000.00	
UBB	154020011	FDIC INSURED CERT 16571		1.2	02/01/2029		200	30,000.00 NR		01/11/2021	27,381.26	
05600XAV2		BMO HARRIS BANK CD		UNITED BANKERS BANK				200,000.00		02/04/2021	200,000.00	
UBB	154020011	FDIC INSURED CERT 16571		.5	02/27/2025		400	200,000.00		02/04/2021	200,000.00	
06426KBA5		BANK NEW ENG CD		UNITED BANKERS BANK				25,000.00		02/04/2021	25,000.00	
UBB	154017499	FDIC INSURED		.5	02/27/2025		400	25,000.00		02/04/2021	25,000.00	
07371CK81		BEAL BANK USA CD		2.85	02/15/2024		400	245,000.00		02/14/2020	245,000.00	
UBB	154022883	FDIC INSURED CERT 57833		UNITED BANKERS BANK				55,000.00		12/01/2022	55,000.00	
07371CK81		BEAL BANK USA CD		2.05	03/03/2027		400	55,000.00		12/01/2022	55,000.00	
UBB	154022883	FDIC INSURED CERT 57833		UNITED BANKERS BANK				70,000.00		12/01/2022	70,000.00	
254673C46		DISCOVER BANK CD		2.05	03/03/2027		400	146,000.00		07/15/2022	146,000.00	
UBB	154023140	FDIC INSURED CERT 5649		UNITED BANKERS BANK				146,000.00		07/15/2022	146,000.00	
				2.85	05/05/2025		400	146,000.00				



Sales: 800-558-6875
 Operations: 800-558-6876

SP Ratings Copyright 2019, S&P Global Market Intelligence on behalf of S&P

Investment Portfolio Pledged Securities
 COMMUNITY FIRST BANK
 MENA HGA, MN

InTrader (pledged)
 Last : 06/30/2023
 As-of: 07/31/2023
 1587 100792

Sec ID Loc	Ticket	Security Description Line 1 Security Description Line 2	Safekeeping Agent Rate	Maturity	Grp	Original Face S & P Par/Curr Face Moody	Priced Pledged	Book Value Market Value	
254673C46		DISCOVER BANK CD	UNITED BANKERS BANK			99,000.00		99,000.00	
UBB	154023140	FDIC INSURED CERT 5649	2.85	05/05/2025	400	99,000.00	07/15/2022	99,000.00	
33847E3X3		FLAGSTAR BK FSB CD	UNITED BANKERS BANK			215,000.00		215,000.00	
UBB	154019966	FDIC INSURED CERT 32541	.5	07/31/2024	400	215,000.00	05/21/2021	215,000.00	
34969RCS5		FORTUNE BANK ARNOLD CD	UNITED BANKERS BANK			55,000.00		54,946.17	
UBB	154019087	FDIC INSURED CERT 58107	1	03/27/2024	400	55,000.00	06/16/2021	54,946.17	
38148P2H9		GOLDMAN SACHS BANK USA CD	UNITED BANKERS BANK			200,000.00		200,000.00	
UBB	154017247	FDIC INSURED CERT 33124	3.55	11/21/2023	400	200,000.00	12/10/2018	200,000.00	
538036HH0		LIVE OAK BANKING CO CD	UNITED BANKERS BANK			245,000.00		245,000.00	
UBB	154018568	FDIC INSURED CERT 58665	1.8	09/13/2023	400	245,000.00	04/20/2021	245,000.00	
856283G59		STATE BANK OF INDIA CD	UNITED BANKERS BANK			100,000.00		100,000.00	
UBB	154017265	FDIC INSURED CERT 33664	3.6	11/29/2023	400	100,000.00	08/29/2019	100,000.00	
88241THS2		TEXAS EXCHANGE BANK CD	UNITED BANKERS BANK			245,000.00		245,000.00	
UBB	154019760	FDIC INSURED CERT 20099	.65	06/21/2024	400	245,000.00	07/19/2023	245,000.00	
TOTAL FOR PLEDGE ID J49									
Pledged: 27						Orig Face: 3,170,000.00	Current Face: 3,170,000.00	Market: 3,081,968.24	Book: 3,168,396.11



Sales: 800-558-6875
 Operations: 800-558-6876

8:51

LTE



ga Public School

Menahga

Distance ?

3.20 mi



 DEPARTMENT OF TRANSPORTATION PARAM/SPECIAL EVENT/BANNER ON TRUCK HIGHWAY RIGHT OF WAY APPLICATION	Permit Number: 3A SE-2023-104946 CA: 8005 IA: 71 <small>(THIS SECTION AND NUMBER OF PAGES ARE SUBJECT TO CHANGE)</small>
--	---

SUBMIT TO DISTRICT OFFICE OF MINNESOTA DEPARTMENT OF TRANSPORTATION

APPLICANT NAME AND TITLE Nathan Erickson <small>EVENT COORDINATOR</small>	TELEPHONE 763-238-6417	E-MAIL ADDRESS nateerickson@hotmail.com
TELEPHONE (Area Code) (City, State, Zip) 33898 US 71 Menahga		

NAME OF PROPOSED EVENT AND Sponsoring ORGANIZATION
 Mikes for Michael

LOCATION OF PROPOSED EVENT (Attach a map showing boundaries of event and any detour)
 Highway: **71** From Mile Post: **3rd of SE** To Mile Post: **1st of SE** (Location: **In front of Menahga school**)

WILL THIS EVENT BE WITHIN FEDERAL LANDS? Yes No IF YES, WHICH ONE?
 FEDERAL LANDS REGULATIONS (Attach the Required Certificates of Insurance)

DATE OF PROPOSED EVENT 9-16-23	LOCATION OF THE PROPOSED EVENT Time From Begins: 10am - 1pm Time Event Ends:
--	---

ENTER UNDER TRAFFIC CONTROL REQUIRED Attach a map showing route of detour and written approval of the route of detour by the road authority of the affected roadway. Provide a description of how traffic will be controlled (e.g. police officer, prepared signs or other traffic control devices, and written approval of the traffic control services that will be provided by the town, private contract, other law enforcement agency, etc.)

APPLICANT'S ACCEPTANCE, WAIVER AND INDEMNIFICATION

The undersigned applicant hereby agrees to comply with applicable statutes, rules and the standard conditions and special provisions of this permit. The applicant understands and agrees that no provision of the truck highway right of way in connection with this application will be started until the application has been approved and the permit issued. The applicant also understands that this permit may also be subject to the approval of local road authorities having legal jurisdiction over said street or highway and acknowledges that all local law enforcement has reviewed and agreed to said application.

The applicant is aware of circumstances or hazards that may arise while conducting the proposed event that could result in injury, loss, damage or death, and the applicant assumes the risk of such circumstances, dangers or hazards, whether reasonably foreseeable or not.

The undersigned applicant expressly agrees that except for employees of the State, its agents and employees, the applicant or its agents shall assume all liability for, and save the State, its agents and employees, harmless from any and all claims for damages, injuries or claims of action arising out of the activities to be done in connection with this application and permit.

NAME AND TITLE Nate Erickson - MN State Patrol	E-MAIL ADDRESS nateerickson@hotmail.com
DATE 9/24/23	SIGNATURE 

DO NOT WRITE BELOW THIS LINE

PERMIT NOT VALID UNLESS BEARING AUTHORIZED MNDOT SIGNATURE AND PERMIT NUMBER

AUTHORIZATION OF PERMIT

It is expressly understood that this permit is conditioned upon restoration of the truck highway right-of-way to its original condition or to a satisfactory substitute. In consideration of the applicant's agreement to comply in all respects with the applicable laws and the conditions of the Commissioner of Transportation pertaining to this permit, permission is hereby granted for the work to be performed as described in the above application, and work to be performed in accordance with the following:

SEE ATTACHED STANDARD CONDITIONS AND SPECIAL PROVISIONS

ISSUANCE DATE 9/16/2023 <small>Expiration Date of This Permit</small>	AUTHORIZED SIGNATURE Jeremy Mollner <small>Authorizing MNDOT Signature</small>	DATE OF RETURNED SIGNATURE 5/25/2023 <small>Date of Return of Signature</small>
DISTRICT TITLE Assigned to Area Maintenance Engineer Applicant: Police Supervisor Bay District Supervisor Signature	DEPOSIT REQUIREMENTS <input checked="" type="checkbox"/> No Deposit Required <input type="checkbox"/> Deposit Required in the Amount of \$ N/A Does Deposit Remain: Deposit to be returned upon satisfactory completion of all work	DEPOSIT TYPE Cashier's Check # Certified Check # Money Order # Bond #

Council Action Request Form



CITY OF MENAHGA
"The Gateway to the Pines"

115 2nd St NE - PO Box C
 Menahga, MN 56464
 218-564-4557
 www.cityofmenahga.com

Action Requested

<input checked="" type="checkbox"/> Action/Motion <input type="checkbox"/> Discussion <input type="checkbox"/> Informational Item <input type="checkbox"/> Consent Agenda Items	<input type="checkbox"/> Report <input type="checkbox"/> Resolution <input type="checkbox"/> Other _____
--	--

Regarding: Resolution 2023-32 Get Hooked on Fishing Donation

Date of Meeting: August 28, 2023 **Total time requested:**

Department Requesting Action: Administration

Presenting at Meeting: Jensine Kurtti

Background Supporting Documentation Enclosed

The family of Gary Ryhti would like to donate \$560.00 to the Menahga Get Hooked on Fishing Program, in remembrance of Gary Ryhti.

Options Supporting Documentation Enclosed

Recommendations The Menahga City Council approves the following by Motion:

To approve Resolution 2023-32 accepting the donation of \$560.00 from the Gary Ryhti family.

Financial Implications: \$	Comments
Funding Source:	
Budgeted: <input type="checkbox"/> Yes <input type="checkbox"/> No	

Action	Voting in Favor	Voting Opposed
Motion:	<input type="checkbox"/> Olson	<input type="checkbox"/> Olson
Second:	<input type="checkbox"/> Tomperi	<input type="checkbox"/> Tomperi
<input type="checkbox"/> Passed	<input type="checkbox"/> Bjornson	<input type="checkbox"/> Bjornson
<input type="checkbox"/> Failed	<input type="checkbox"/> Netland	<input type="checkbox"/> Netland
<input type="checkbox"/> Tabled	<input type="checkbox"/> Warmbold	<input type="checkbox"/> Warmbold

Signatures

Agenda Date: August 28, 2023

Action: Approved

Vote:

Yes:

No:

CITY OF MENAHGA, MINNESOTA

Resolution No. 2023-32

A Resolution of the City Council of the City of Menahga, Minnesota, Accepting a Donation

WHEREAS, the City Council of the City of Menahga, Minnesota, does hereby accept the generous donation from the Gary Ryhti Family in Remembrance of Gary Ryhti to the Menahga Get Hooked on Fishing for \$560.00; and

NOW THEREFORE, LET IT BE RESOLVED that the City Council of the City of Menahga MN does hereby authorize the use of the donation money of \$560.00 for the Menahga Get Hooked on Fishing.

Adopted by the City Council of the City of Menahga, Minnesota this the 28th day of August, 2023.

Elizabeth Olson, Mayor

Jensine Kurtti, Interim City Clerk/Treasurer

PUBLIC HEARING NOTICE
WADENA COUNTY BOARD OF COMMISSIONERS

The Wadena County Board of Commissioners will be holding a Public Hearing regarding the process for distributing Opioid settlement dollars and provide an opportunity to Wadena County citizens and municipalities to give comment relating to the same.

The meeting is scheduled to be held on **Tuesday, September 12, 2023 at 9:05 a.m.** at the Wadena County Courthouse, Lower Level Multi-purpose Room at 415 Jefferson St. S. Wadena, MN 56482.

Ryan Odden, County Coordinator

Dated at Wadena, Minnesota, this 23rd Day of August 2023.

Lacey Erickson

From: Laura Eubanks <laura@forumcomm.com>
Sent: Monday, August 21, 2023 9:39 AM
To: Lacey Erickson
Subject: Re: Help Wanted

Hi Lacey,

I recommend running this online 30 days on [jobshq.com](https://www.jobshq.com), rotating on the Park Rapids & Forum newspaper websites, on additional job, diversity/veteran & social media sites along with the print ad running Aug. 23, 26, 30, Sept. 2 in the Forum for a total online & print investment of \$1330

Let me know if this is approved to run or if you have a different coverage or budget in mind.

Thanks, Laura



Laura Eubanks

Recruitment Marketing Consultant | Team Leader

701-241-5481 | Laura@jobsHQ.com

888-514-HIRE (4473)

JobsHQ, a Forum Communications Company

Digital | Print | Content | Social | Events



On Fri, Aug 18, 2023 at 2:01 PM Lacey Erickson <cmehahga@cityofmenahga.com> wrote:

Laura,

I think the employment section. The ad is fine, and what would the cost be for us to run this in the Fargo Forum.

Thanks, Jensine

From: Laura Eubanks <laura@forumcomm.com>
Sent: Friday, August 18, 2023 1:48 PM
To: Lacey Erickson <cmehahga@cityofmenahga.com>
Subject: Re: Help Wanted

Hi Lacey,

Here is the attached proof that ran in the Park Rapids Enterprise in the general section of the newspaper- would you like this running in the employment section or the main section of the Forum?



Laura Eubanks
Recruitment Marketing Consultant | Team Leader
701-241-5481 | Laura@jobsHQ.com
888-514-HIRE (4473)
JobsHQ, a Forum Communications Company
Digital | Print | Content | Social | Events



Jensine Kurtti

From: Deleeuw, Elizabeth <Elizabeth.Deleeuw@startribune.com>
Sent: Tuesday, August 22, 2023 9:40 AM
To: Jensine Kurtti
Subject: RE: City of Menahga Help Wanted

Good morning, Jensine. Thanks for sending this over.

If we were to run this ad in print, it would be approximately \$1000/Sunday. It does not include the job posting.

Because it's a unique position and outside of the Twin Cities, here's my recommendation:

You can purchase "a la carte" or in combination.

Combination tactics will deliver the most response.

Recommendations/tactics:

1. Job posting with Ad Max Platinum enhancement: 30 days on startribune.com/jobs along with our network of websites. Reporting including views/applies only. This option delivers traffic from active job seekers. \$600.
2. Advantage email to 50,000 candidates (design services included). \$2500.
3. Follow up with a "resend to opened emails" the following week for an additional \$750.
4. Advantage Digital display geo fencing campaign, \$1500 +.
\$5350 total

Please let me know what questions you may have. Thanks.

Liz

Liz Deleeuw
Account Executive
612-743-0133 Cell
elizabeth.deleeuw@startribune.com

From: Jensine Kurtti <jkurtti@cityofmenahga.com>
Sent: Tuesday, August 22, 2023 8:11 AM
To: Deleeuw, Elizabeth <Elizabeth.Deleeuw@startribune.com>
Subject: City of Menahga Help Wanted

Elizabeth,

I am sending you a copy of our Help Wanted Ad. Would you send me a few options of how we could run this ad and the cost associated with it. An online format could be one of those options.

Thank you, Jensine Kurtti

From: Scan <scan@cityofmenahga.com>
Sent: Tuesday, August 22, 2023 8:05 AM
To: Jensine Kurtti <jkurtti@cityofmenahga.com>
Subject: Scanned Image from the City of Menahga

BACKGROUND INFORMATION:

ECPN: Equitable cost-sharing for publicly owned nursing facilities.

This program, authorized by the legislature in 2010, affords nursing facilities (Greenwood Connections) owned by nonstate government entities to participate and benefit from a federal match of subsidies provided to the facility by the owner. This program offsets the cost of providing quality services to Medicaid recipients and private pay residents.

This program is a matched subsidy, not a grant program. The City of Menasha is meant to contribute subsidies so that Greenwood Connections can receive a federal match for received subsidies, allowing the facility to keep their prices equitable. There is no provision, in the ECPN program, that allows a facility (Greenwood Connections) to pay for its own benefit.

The City is supposed to be paying its Owner Subsidy to the State and Greenwood Connections was not and is not supposed to be paying the City to offset the contribution into the ECPN program.

Information gleaned from the MN Department of Human Services (DHS):

The MN Department of Human Services (DHS) implements the ECPN. Under ECPN the total amount of additional Medical Assistance (MA) payments under ECPN is limited by the Centers for Medicare and Medicaid Services (CMS).

The available additional MA funding is fairly distributed among the eligible facilities. The available funding is divided by MA days of eligible facilities for a specified period of time (which eligible participants are made aware of) and the result of that computation equates to a per day amount for which a facility may choose a rate up to that amount.

CMS (Centers for Medicare and Medicaid Services) strictly prohibits the use of facility (Greenwood Connection) funds to pay for the owners' portion of the non-federal share of the ECPN payments. The non-federal share of the ECPN amount must be paid by the owner from its resources. The application, which must be signed by an official of the non-state governmental entity that owns the facility includes statements that address this issue. The owner may charge the facility reasonable amounts for payments in lieu of taxes and for rent. It is expected that

the owner will pay the non-federal share from tax or other revenues at its disposal. The DHS will examine this in audits.

Minutes of previous council meetings in which the subject of ECPN was noted:

- July 20, 2015 – it was noted that it appeared the ECPN would not be needed as the new rates were going to surpass the ECPN.
- October 17, 2017 – Ms. Ahlf’s recommendation to not apply for ECPN funds was expanded upon.

If the City elects to participate in this program, the City Council needs to determine how best to pay their non-federal share of the ECPN program other than what is and has currently been done.

Currently GC pays the City \$9,400/month and they call it a lease payment. How the City is identifying this is of concern.

This has been identified in the accounting system as “ECPN reimbursement” and ECPN payment - clearly directs attention to how the City is funding the payment.

There are two parcels that pertain to this facility and data retrieved from the assessor indicates that Parcel #17.022.1090, if taxable, would generate \$128,402 and Parcel #17.022.1122, if taxable would generate \$566. For a total of \$128,968. Currently the City receives \$25,000 from GC for payment in lieu of taxes – plus whatever or a figure close the amount of the payment the City makes to the ECPN program.

There is a formula that is computed as to what is allowable for payment in lieu of taxes.

HISTORY OF RECEIPTS/PAYMENTS

Year	Rec’d from GC	City paid to ECPN
2014	\$100,000	\$ 98,899.48
2015	\$275,000	\$271,973.57
2016	\$ 19,673.85	\$ 19,673.85
2020	\$ 77,841	\$ 82,234.96
2021	\$116,400	\$123,304.37
2022	\$117,500	\$117,482.12
2023 – to date	\$ 57,530	\$ 65,669.17
TOTALS	\$763,944.85	\$779,237.52

SUGGESTED SOLUTION:

The City invoice GC every month \$9,400 for rent/lease and identify the receipt of the monthly payments as rent/lease income. The City can then use that revenue, plus the \$25,000 (PILOT) to pay ECPN.

G. Reports by Departments

1. Greenwood Connections Administrator – Laura Ahlf

Council Member McNeece:

- Commended Ms. Ahlf for her work on the expansion project and successful ground breaking ceremony;
- Expanded on Ms. Ahlf's recommendation to not apply for ECPN funds; and
- Referred to the financial statements.

Main Motion: To approve the minutes and financials

Moved by:	Ellingson
Seconded by:	McNeece
Action:	Motion carried by unanimous voice vote.
In favor:	Foss, Ellingson, Komulainen, McNeece
Opposed:	None

2. City Administrator – Janette Bower

- Expanded on the C&C Christmas tree project at St Urho park;
- Spoke of the Playground project and the need to obtain additional quotes from playground equipment companies and available funding cycles;
- Referred to the progress on the Small Cities Development grant project; and
- Highlighted the RezNexus campground reservation program.

Mayor Foss:

- Congratulated Dave Kicker on his Fire Chief of the Year award.

H. Notices and Communications

I. Public Hearings

J. Unfinished Business

K. New Business

Item 1 – Action Memorandum 17-055: Authorize Ulteig Engineering to Proceed with the Menahga Cemetery Boundary Topographic Survey Project

Main Motion: To authorize Action Memorandum 17-055

Moved by:	Lawrey
Seconded by:	Komulainen
Action:	Motion carried by unanimous voice vote.
In favor:	Foss, Ellingson, Komulainen, McNeece
Opposed:	None

Council Member McNeece:

- Questioned the cost and the services provided; and
- Voiced the expectation for an itemized quote.

L. Consideration of Bills

Main Motion: To approve payment of the bills

Moved by:	Komulainen
Seconded by:	Ellingson
Action:	Motion carried by unanimous voice vote.
In favor:	Foss, Ellingson, Komulainen, McNeece
Opposed:	None

M. Meeting Adjourned

Main Motion: To adjourn the meeting at 8:20 pm

Moved by:	Ellingson
Seconded by:	McNeece
Action:	Motion carried by unanimous voice vote.
In favor:	Foss, Ellingson, Komulainen, McNeece
Opposed:	None

Janette M. Bower, Administrator

Patrick Foss, Mayor

Council Member Lawrey questioned whether anyone could envision the scenario of using the \$550,000 and what was Plan B, say we use the money and then need it. He added that he was in favor of spending the funds for payment of the bonds.

Mr. Hagen responded that then the City would have to scabble and do a Nursing Home bond.

Administrator West commented that she had previously discussed with Mr. Erickson the issue of his not knowing what the upcoming rates were going to be nor was the upcoming budget finalized. She questioned whether Mr. Erickson was thinking about prepayment of the 2007B on January 1, 2016 or now.

Mr. Erickson responded that he was thinking of September 1, 2015, or as soon as it could be done. He added that the legislature was working on the upcoming rates and it appeared the ECPN would not be needed as the new rates were going to surpass the ECPN.

Council Member Rasmussen commented that a year ago the City needed to get in the ECPN program or the Nursing Home was going to be in the red; now the discussion was to pay about a half a million dollars in reserves to save \$23,000.

Discussion was held on the actual savings the Nursing Home would experience if the \$550,000 prepayment of the 2007B bonds was made; consensus was \$23,000.

Mr. Erickson pointed out that the \$550,000 would be spent either way by 2020.

Discussion was held regarding the inclusion of the cost for the replacement of the main lift station in the 2007 GO Bond refinancing.

Mayor Foss questioned whether the Council would like to consider the financing of the main sewer lift station as part of the bond refinancing at that time or wait until the Debt Study was received. He added that, during the previous Council Meeting, the Council did approve the Nursing Homes request to prepay the 2007B bonds but the Sewer bond refinancing could be tabled until the debt study was received so the Council could make the best decision on whether to pay for the sewer main lift station from cash reserves or to include it in the refinancing at a lower interest rate.

Council Action Request Form



CITY OF MENAHGA
"The Gateway to the Pine"

115 2nd St NE - PO Box C
 Menahga, MN 56464
 218-564-4557
 www.cityofmenahga.com

Action Requested

<input checked="" type="checkbox"/> Action/Motion <input type="checkbox"/> Discussion <input type="checkbox"/> Informational Item <input type="checkbox"/> Consent Agenda Items	<input type="checkbox"/> Report <input type="checkbox"/> Resolution <input type="checkbox"/> Other _____
--	--

Regarding: Consideration of Bills

Date of Meeting: August 28, 2023 **Total time requested:**

Department Requesting Action: Administration

Presenting at Meeting: Jensine Kurtti

Background Supporting Documentation Enclosed

To consider payment of the following bills:

Batch #082823PAY - \$78,879.29
 Batch #UBPOSTAGE - \$ _____

Options Supporting Documentation Enclosed

Recommendations The Menahga City Council approves the following by Motion:

To approve the payment of Batch #082823PAY for \$78,879.29 and Batch #UBPOSTAGE for \$ _____,

Financial Implications: \$	Comments
Funding Source:	
Budgeted: <input type="checkbox"/> Yes <input type="checkbox"/> No	

Action	Voting in Favor	Voting Opposed
Motion:	<input type="checkbox"/> Olson	<input type="checkbox"/> Olson
Second:	<input type="checkbox"/> Tomperi	<input type="checkbox"/> Tomperi
<input type="checkbox"/> Passed	<input type="checkbox"/> Bjornson	<input type="checkbox"/> Bjornson
<input type="checkbox"/> Failed	<input type="checkbox"/> Netland	<input type="checkbox"/> Netland
<input type="checkbox"/> Tabled	<input type="checkbox"/> Warmbold	<input type="checkbox"/> Warmbold

Signatures

CITY OF MENAHGA

08/25/23 8:17 AM

Page 1

082823PAY

***Check Detail Register©**
10100 Unposted

Check #	Check Date	Vendor Name	Amount	Invoice	Comment
10100 GENERAL CHECKING					
63379	08/24/23	ARCTIC GLACIER			
E 609-49750-254		Snack, Ice, Soda Purchas	\$137.38	3602322105	Ice- August
E 609-49750-333		Freight	\$15.00	3602322105	Ice - August
E 609-49750-254		Snack, Ice, Soda Purchas	\$557.13	3606322805	Ice - August
E 609-49750-333		Freight	\$15.00	3606322805	Ice- August
		Total	\$724.51		
63380	08/24/23	ASTERA			
E 101-42110-208		Training and Instruction	\$325.00	August 2023	Ofcr White - Training CPR/EMR
		Total	\$325.00		
63381	08/24/23	AUTO VALUE			
E 601-49400-210		Operating Supplies	\$29.47	38380165	OXYGEN AND HAZMAT FEE
		Total	\$29.47		
63382	08/24/23	BERNICKS			
E 609-49750-252		Beer Purchases	\$338.90	20028620	LS off Sale - Liquor/Beer- aug
E 609-49750-254		Snack, Ice, Soda Purchas	\$35.60	20028621	LS Off Sale-Soda and Tonic- August
		Total	\$374.50		
63383	08/24/23	BEVERAGE WHOLESALE			
E 609-49750-252		Beer Purchases	\$465.00	287247	LS Off Sale - Beer- August
E 609-49750-252		Beer Purchases	\$1,271.50	288334	LS Off Sale Beer-aug
E 609-49750-254		Snack, Ice, Soda Purchas	\$31.45	288334	LS Off Sale- Soda- Aug
E 609-49750-252		Beer Purchases	(\$44.24)	288334	LS Off Sale Returns - Aug
		Total	\$1,723.71		
63384	08/24/23	BREAKTHRU BEVERAGE			
E 609-49750-251		Liquor Purchases	\$1,229.50	111516648	LS Off Sale Liquor- Aug
E 609-49750-333		Freight	\$15.57	111516648	LS Off Sale - Freight- Aug
E 609-49750-251		Liquor Purchases	\$1,612.85	111717442	LS Off Sale - Liquor - Aug
E 609-49750-254		Snack, Ice, Soda Purchas	\$27.00	111717442	LS Off Sale - Mixes- Aug
E 609-49750-333		Freight	\$18.96	111717442	LS Off Sale Freight - aug
		Total	\$2,903.88		
63385	08/24/23	CINTAS			
G 750-21722		Uniform Deduction	\$49.56	4163384868	PW Uniform-Aug
G 750-21722		Uniform Deduction	\$49.56	4164101452	PW Uniform-Aug
G 750-21722		Uniform Deduction	\$49.56	4164867799	PW Uniform-Aug
		Total	\$148.68		
63386	08/24/23	CINTAS			
E 609-49750-210		Operating Supplies	\$62.78	4164867861	LS OFF Sale - Cleaning Aug
E 609-49760-210		Operating Supplies	\$62.77	4164867861	LS On Sale - Cleaning - Aug
		Total	\$125.55		
63387	08/24/23	CORE & MAIN			
E 601-49400-220		Repair & Maintenance	\$70.81	T362838	Ball Valve- Aug
E 601-49400-220		Repair & Maintenance	\$10.35	T362838	Freight- Aug

***Check Detail Register©**
10100 Unposted

Check #	Check Date	Vendor Name	Amount	Invoice	Comment
			Total	\$81.16	
63388	08/24/23	DAHLHEIMER BEVERAGE BRAINERD			
E 609-49750-252		Beer Purchases	\$3,395.25	1975763	LS Off Sale - Beer- Aug
E 609-49750-252		Beer Purchases	(\$138.75)	1975763	LS Off Sale- Returns - Aug
E 609-49760-254		Snack, Ice, Soda Purchas	\$72.00	1975763	Ls On Sale- Beer- Aug
E 609-49750-252		Beer Purchases	\$6,632.75	1981263	LS Off Sale - BeerAug
E 609-49750-252		Beer Purchases	(\$210.35)	1981263	LS Off Sale- Returns - Aug
E 609-49750-252		Beer Purchases	(\$30.00)	1981263	LS Off sale - Returns- Aug
			Total	\$9,720.90	
63389	08/24/23	DEPARTMENT OF HUMAN SERVICES			
E 101-49200-439		ECPN State Payment	\$9,381.31	00000007527	ECPN Payment - Sept
			Total	\$9,381.31	
63390	08/24/23	DMP HEATING & COOLING LLC			
E 101-41400-220		Repair & Maintenance	\$150.00	2124	Serv/Diag/HVAC City Govt Bldg
			Total	\$150.00	
63391	08/24/23	D-S BEVERAGES INC			
E 609-49750-252		Beer Purchases	\$6,148.15	718399	LS Off Sale- Beer- Aug
E 609-49750-254		Snack, Ice, Soda Purchas	\$154.35	718399	LS Off Sale - Mixers- Aug
E 609-49750-252		Beer Purchases	(\$195.55)	718399	LS Off Sale-Beer Returns - Aug
E 609-49750-252		Beer Purchases	\$2,196.30	720500	LS Off Sale - Beer - Aug
E 609-49750-251		Liquor Purchases	\$109.00	720500	LS Off Sale Liquor- Aug
E 609-49750-254		Snack, Ice, Soda Purchas	\$27.45	720500	LS Off Sale Mixers- Aug
			Total	\$8,439.70	
63392	08/24/23	EHLERS			
E 233-00000-305		Professional Services	\$132.50	94960	Prep 1st Half 2023PAYGO Note Calc
E 233-00000-305		Professional Services	\$1,921.25	94961	TIF Reporting- 2022 Reports
E 233-00000-305		Professional Services	\$850.00	95111	2023 Continuing Disclosure Reporting
			Total	\$2,903.75	
63393	08/24/23	FORUM COMMUNICATIONS COMPANY			
E 609-49750-340		Advertising	\$30.00	MP69954072	LS Off Sale Adv-Mid Summer2023
E 609-49760-340		Advertising	\$30.00	MP69954072	LS ON Sale Adv- Mid-Summer 2023
			Total	\$60.00	
63394	08/24/23	GIOVANNI S			
E 609-49760-254		Snack, Ice, Soda Purchas	\$450.20	0408172311	LS On Sale - Pizza- Aug
			Total	\$450.20	
63395	08/24/23	GRANITE CITY JOBBING CO.			
E 609-49750-256		Tobacco Products For Re	\$317.52	346274	LS Off Sale Tobacco- Aug
E 609-49750-210		Operating Supplies	\$19.88	346274	LS Off Sale Snacks- Aug
E 609-49750-333		Freight	\$5.00	346274	LS Off Sale Freight - Aug
E 609-49760-254		Snack, Ice, Soda Purchas	\$110.11	346274	LS On Sale - Snacks- Aug
E 609-49760-210		Operating Supplies	\$22.88	346274	LS On Sale - Olives-Aug
E 609-49760-333		Freight	\$5.00	346274	LS On Sale Freight-Aug
E 609-49760-254		Snack, Ice, Soda Purchas	\$52.70	346274	LS On Sale Candy Bars- Aug

***Check Detail Register©**

10100 Unposted

Check #	Check Date	Vendor Name	Amount	Invoice	Comment
E 609-49760-333		Freight		\$10.00	346274 LS On Sale Handling Charge
		Total		\$543.09	
63396	08/24/23	GREAT PLAINS FIRE			
E 101-42200-220		Repair & Maintenance	\$1,408.84	7644	FD Repairs on #4862 - July
		Total	\$1,408.84		
63397	08/24/23	HAWKINS, INC.			
E 601-49400-210		Operating Supplies	\$1,865.22	6553775	Azone, Freight, and Sodium Permanganate
		Total	\$1,865.22		
63398	08/24/23	HEGGIES PIZZA			
E 609-49760-254		Snack, Ice, Soda Purchas	\$175.80	1011682017	LS On Sale - Pizza
		Total	\$175.80		
63399	08/24/23	JOHNSON BROTHERS LIQUOR			
E 609-49750-251		Liquor Purchases	\$1,909.45	2361411	LS Off Sale - Lqr-Aug
E 609-49750-333		Freight	\$47.96	2361411	LS Off Sale Freight - Aug
		Total	\$1,957.41		
63400	08/24/23	LAKES AREA COOP -1 PERHAM			
E 101-42200-210		Operating Supplies	\$17.99	475378	FD Assisted Menahga C & C - Power Strip
		Total	\$17.99		
63401	08/24/23	LAW ENFORCEMENT LABOR SERVICES			
G 750-21719		LELS Union Dues	\$33.75		Union Dues A Ofcr Houtari - Proll 16
G 750-21719		LELS Union Dues	\$33.75		Union Dues A Ofcr Houtari - Proll 17
G 750-21719		LELS Union Dues	\$33.75		Union Dues A Ofcr White - Proll 16
G 750-21719		LELS Union Dues	\$33.75		Union Dues A Ofcr White - Proll 16
		Total	\$135.00		
63403	08/24/23	MINNESOTA DEPT OF HEALTH			
E 601-49400-433		Dues and Subscriptions	\$1,387.00	3Q 2023	Quarterly Service Connections - Water
		Total	\$1,387.00		
63404	08/24/23	MINNESOTA FIRE SERV CERT BOARD			
E 101-42200-314		Training - Reimbursement	\$378.00	11103	Rcd 8/11/23FF 1 Cert Exam forAnderson, Isaacson, Juntunen
E 101-42200-314		Training - Reimbursement	\$50.00	11103	Rcd 08/11/23FD Retest Fee FF 1 4/12/23 Anderson/jununen
E 101-42200-314		Training - Reimbursement	\$50.00	11696	Retest fee FF 1 07/14/23 Anderson/Juntunen
		Total	\$478.00		
63405	08/24/23	NAPA CENTRAL - MN			
E 601-49400-210		Operating Supplies	\$14.99	563485	Gloves- Water Plant
E 602-49450-210		Operating Supplies	\$31.48	563817	Gloves - Sewer
E 101-45200-212		Motor Fuels & Lubricants	\$44.95	563977	Oil Filter- Parks
E 101-45200-220		Repair & Maintenance	\$7.69	564177	Payloader
E 101-45200-220		Repair & Maintenance	\$44.48	564179	Payloader- Lamp- Aug
E 601-49400-212		Motor Fuels & Lubricants	\$7.78	564440	Brake Parts
E 601-49400-210		Operating Supplies	\$50.98	564440	Lamp Shop
E 601-49400-210		Operating Supplies	\$18.99	564440	24 volt Halogen

***Check Detail Register©**

10100 Unposted

Check #	Check Date	Vendor Name	Amount	Invoice	Comment
		Total		\$221.34	
63406	08/24/23	PHILLIPS WINE & SPIRITS			
E 609-49750-251		Liquor Purchases	\$529.50	6641167	LS Off Sale - Lqr- Aug
E 609-49750-254		Snack, Ice, Soda Purchas	\$52.15	6641167	LS Off Sale Mixers- aug
E 609-49750-333		Freight	\$17.62	6641167	LS Off Sale Freight - Aug
		Total		\$599.27	
63407	08/24/23	PRINTING SYSTEMS, INC.			
E 601-49400-210		Operating Supplies	\$218.12	228577	UB Forms - Aug 2023
E 602-49450-210		Operating Supplies	\$218.13	228577	UB Forms- Aug 2023
		Total		\$436.25	
63408	08/24/23	RMB ENVIRONMENTAL LABS			
E 601-49400-305		Professional Services	\$59.90	D049360	Data Management Analysis Water
		Total		\$59.90	
63409	08/24/23	S.C.D. TAP BEER LINE CLEANING			
E 609-49760-210		Operating Supplies	\$42.00	7794	Clean Tap Lines - Aug
		Total		\$42.00	
63410	08/24/23	SOURCEWELL			
E 101-41500-305		Professional Services	\$440.00	INV00002249	Zoning Admn ConsultingJULY 2023
		Total		\$440.00	
63411	08/24/23	SOUTHERN GLAZERS OF MN			
E 609-49750-251		Liquor Purchases	\$1,305.60	2380853	LS Off Sale Liquor - Aug
E 609-49750-333		Freight	\$22.38	2380853	LS Off Sale Freight - Aug
		Total		\$1,327.98	
63412	08/24/23	SWIPECLOCK, LLC			
E 101-41400-433		Dues and Subscriptions	\$105.00	1107739-250	Payclock For JULY see notes on invc
		Total		\$105.00	
63413	08/24/23	TASC			
E 101-41400-131		Employer Paid Health	\$16.04	IN28344869	COBRA Admn Fee c10/1/23-10/31-23
		Total		\$16.04	
63414	08/24/23	TEAM LABORATORY CHEMICAL			
E 602-49450-210		Operating Supplies	\$939.00	INV0037349	EZ Dose It Block- Sewer
		Total		\$939.00	
63415	08/24/23	TED S HARDWARE SEBEKA			
E 101-45200-220		Repair & Maintenance	(\$0.44)		Applky credits
E 602-49450-220		Repair & Maintenance	\$21.69	63191	Sewer - Oil
E 609-49750-210		Operating Supplies	\$13.98	63206	Cable Ties Fencing Midsummer
E 101-42200-220		Repair & Maintenance	\$13.98	63218	Hitch Pins Fire Dept
E 101-43100-210		Operating Supplies	\$16.99	63221	Pliers
E 101-45200-220		Repair & Maintenance	\$14.49	63226	Flood Lights Beach
E 101-45120-220		Repair & Maintenance	\$20.99	63236	Batteries Campground
E 101-42200-220		Repair & Maintenance	\$4.00	63256	Nuts and Bolts

***Check Detail Register©**

10100 Unposted

Check #	Check Date	Vendor Name	Amount	Invoice	Comment
E 101-45200-220		Repair & Maintenance	\$16.48	63258	Cleaner - Campground
E 601-49400-220		Repair & Maintenance	\$21.47	63285	Cleaning/MtnC Supplies Water Plant
E 101-45200-220		Repair & Maintenance	\$4.00	63297	Nuts/bolts Campground
		Total	\$147.63		
63416	08/24/23	THEIN WELL CO INC			
E 601-49400-312		Contracted Maintenance	\$6,260.00	8579	Pump System Mobilization/ Labor
E 601-49400-500		Capital Outlay	\$20,449.43	8579	Materials
E 601-49400-210		Operating Supplies	\$50.00	8579	Well Disinfection
E 601-49400-312		Contracted Maintenance	(\$535.19)	8579	2% Contract Discount
		Total	\$26,224.24		
63417	08/24/23	ULTEIG ENG			
E 417-00000-303		Engineering Fees	\$2,329.60	ARIV101641	Engineer- Elevated Water Storage Tank
		Total	\$2,329.60		
63418	08/24/23	VIKING COCA-COLA BOTTLING			
E 609-49750-254		Snack, Ice, Soda Purchas	\$152.40	3263454	LS Off Sale Soda
		Total	\$152.40		
63419	08/24/23	WADENA COUNTY DAC			
E 101-41940-386		Cleaning Services	\$118.40	23558	Govt Bldg Cleaning- JULY 2023
		Total	\$118.40		
63420	08/24/23	WARNICKS JANITORIAL SERVICE			
E 609-49760-386		Cleaning Services	\$170.00	15461	LS ON Sale Tile Cleaning
		Total	\$170.00		
63421	08/24/23	WHITE, JOSEPH			
E 101-42110-208		Training and Instruction	\$29.73	TRNG EMR	45.4 Mileage EMR training
E 101-42110-208		Training and Instruction	\$9.84	TRNG EMR	Meal Reimbursement EMR Training
		Total	\$39.57		
		10100 GENERAL CHECKING	\$78,879.29		

***Check Detail Register©**
10100 Unposted

Check #	Check Date	Vendor Name	Amount	Invoice	Comment
---------	------------	-------------	--------	---------	---------

Fund Summary

10100 GENERAL CHECKING					
101	GENERAL FUND		\$12,667.76		
233	TIF DISTRICT 1-6 PLEASANT PINE		\$2,903.75		
417	Water Tower Construction		\$2,329.60		
601	WATER FUND		\$29,979.32		
602	SEWER FUND		\$1,210.30		
609	MUNICIPAL LIQUOR FUND		\$29,504.88		
750	PAYROLL CLEARING FUND		\$283.68		
			<hr/>		
			\$78,879.29		

Elizabeth Olson, Mayor

Durwin Tomperi, Council Member

Jody Bjornson, Council Member

Michael Netland, Council Member

Daniel Warmbold, Council Member

